



JAYAWANT SHIKSHAN PRASARAK MANDAL'S

Bhivarabai Sawant Institute of Technology & Research

(Approved by AICTE New Delhi, DTE Mumbai & Affiliated to Savitribai Phule Pune University)
Gat No. 719/1 & 2, Wagholi, Pune-Nagar Road, Pune-412207



Prof. Dr. T. J. Sawant
B.E. (Elec.) PGDM, Ph.D
Founder Secretary

Ph : 020-067335108, 65217050, 67335100
Telefax : 020-67335100
Website : www.ispmbstotr.edu.in
(DTE CODE: EN 6311, University Code: CEGP-013100)

Dr. T.K. Nagaraj
ME. (civil Engg). Ph.D (Civil Engg)
LMISTE, LMIGS, LMIRC
LMISRMTT, LMIE
Principal

**Institute Accredited by National Assessment and Accreditations Council (NAAC) and NBA accredited Programs:
Information Technology, Electronics & Telecommunication Engineering, and Electrical Engineering**

7.1.2.-The Institution has facilities and initiatives for

1. Alternate sources of energy and energy conservation measures
2. Management of the various types of degradable and nondegradable waste
3. Water conservation
4. Green campus initiatives
4. Disabled-friendly, barrier free environment

Findings of DVV: "a) Provide Geo tagged photographs of 1.Alternate sources of energy and energy conservation measures 2.Management of the various types of degradable and nondegradable waste 3.Water conservation 4.Green campus initiatives 5.Disabled-friendly, barrier free environment for 2022-23.

b) Provide Bills for the purchase of equipment's for 1.Alternate sources of energy and energy conservation measures 2.Management of the various types of degradable and nondegradable waste 3.Water conservation 4.Green campus initiatives 5.Disabled-friendly, barrier free environment for 2022-23."

Clarification for findings of DVV:

a) Geo tagged photographs of the following are attached herewith

1. Roof top solar system for alternate sources of energy
2. Energy conservation measures using advanced technology implemented in Departments of Information Technology, Electrical Engineering and Electronics and Telecommunication Engineering. Reports with geotagged photographs are attached herewith.
- 3.Water treatment plant and sewage treatment plant
- 4.Rain Water Harvesting facility. 5. Provision of LED tub lights
6. Photograph of campus showing landscaping and Greenery
7. Lift, ramp and washroom for differently abled persons.

b) Bills for the purchase of the following equipments are attached herewith:

1. Roof top solar system for alternate sources of energy
2. Water treatment plant and sewage treatment plant.



Vision: "To Satisfy the aspirations of youth force, who want to lead the nation towards prosperity through techno-economic development"

Mission: "To provide, nurture and maintain an environment of high academic excellence, research and entrepreneurship For all aspiring Students, which will prepare them to face global challenges maintaining high ethical and moral Standards"



Geotagged photographs of

1. Roof top solar system for alternate sources of energy
2. Energy conservation measures using advanced technology implemented in Departments of Information Technology, Electrical Engineering and Electronics and Telecommunication Engineering. Reports with geotagged photographs are attached herewith.
3. Water treatment plant and sewage treatment plant
4. Rain Water Harvesting facility.
5. Provision of LED tub lights
6. Photograph of campus showing landscaping and Greenery
7. Lift, ramp and washroom for differently abled persons.



Roof top Solar System

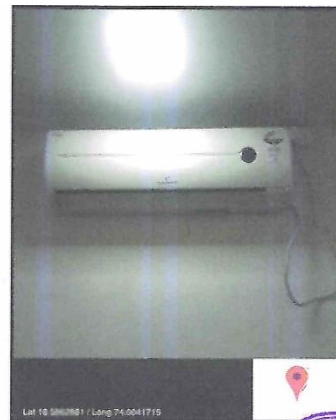
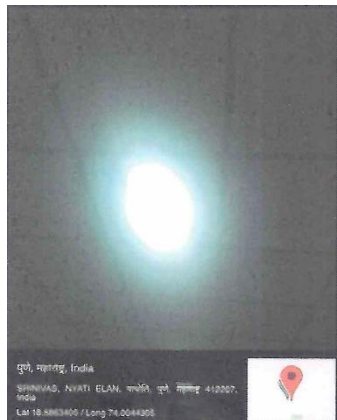

LED Bulbs



Organic Converter Unit



Waste Collection Bin:



Sewage Treatment Plant

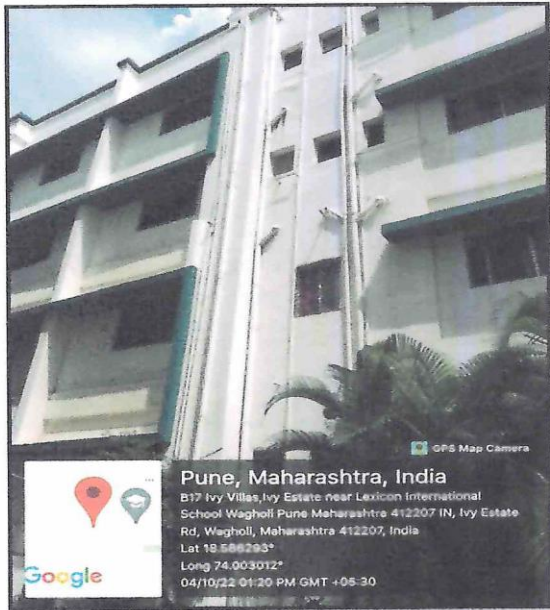

Rain water Harvesting



Tree plantation

Green Initiatives by Different Departments

And

Bills for the purchase of the following Equipments

1. Roof top solar system for alternate sources of energy
2. Water treatment plant and sewage treatment plant.

**JSPM's Bhivarabai Sawant Institute of Technology & Research, Wagholi,
Pune (412207)**

**DEPARTMENT OF
ENGINEERING SCIENCE**

**JAYAWANT SHIKSHAN PRASARAK MANDALS'S
BHIVARABAI SAWANT INSTITUTE OF TECHNOLOGY AND
RESEARCH, WAGHOLI, PUNE**

Name of the Event- First Year Technical Poster Making Competition.

Day and Date of the Event- Thursday, Jan 17, 2019

Time of Event- 12.30 Pm

Venue of Event: Drawing Hall, 4th Floor, Bsiotr, Wagholi, Pune.

DESCRIPTION

a) Introduction, theme and significance.

Introduction- First Year Technical Poster Making Competition. for **CYNOSURE 2K19**

Theme and significance-The subject matter of the poster must address a technical, economic or environmental aspect of engineering, or other basic engineering theme, provided it pertains to some sphere in which an engineer is or should be involved.

b) Conduction, guest details, activity.

The event was inaugurated by Dr. Mukund Wani (HOD FE ICOER) and Dr. Prafulla Sharma (HOD FE BSIOTR). The judge for the event was Dr. Mukund Wani (HOD FE ICOER) and The event started at 12.30 pm and finished at 3.30pm. The students were given 10 min for poster presentation. The criteria for judgement were the creativity, design, clarity, elements and presentation. The first prize for the event was Rs1500 and for runner up Rs 700. The winner and runner up were given trophies.

c) Student and faculty response and participation.

The students had delivered presentation on their poster for about 10 min. The activity was allowed in individual entry. About 61 students had enrolled their names. The entry fee was Rs 50 per individual student. The Faculty Coordinators were Mrs. Wrushali S. Dhange (Bsiotr) and Mr. D. N. Mandlik (Icoer). The Student Coordinators for Event were Trupti Pawar (Bsiotr) and Shweta Bachute (Icoer).

List of Winners:

First Prize:

1) Rinal Lokhande (BSIOTR)

Second Prize:

- 1) Keshav Valmik Patil (BSIOTR)
- 2) Dhumal Pratiksha Ankush (ICOER)

Third Prize:

- 3) Sumeet Balwade (ICOER)
- 4) Vaishnavi Yetekar (BSIOTR)

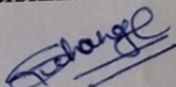

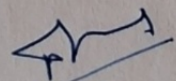
Event Coordinator
Prof. Wrushali S. Dhange
(BSIOTR)

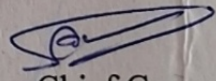
Institute Coordinator
Prof. Nilesh Thorat
(BSIOTR)

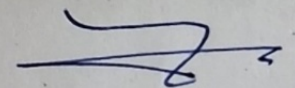

Chief Convener
Dr. Sachin Nehe
(BSIOTR)

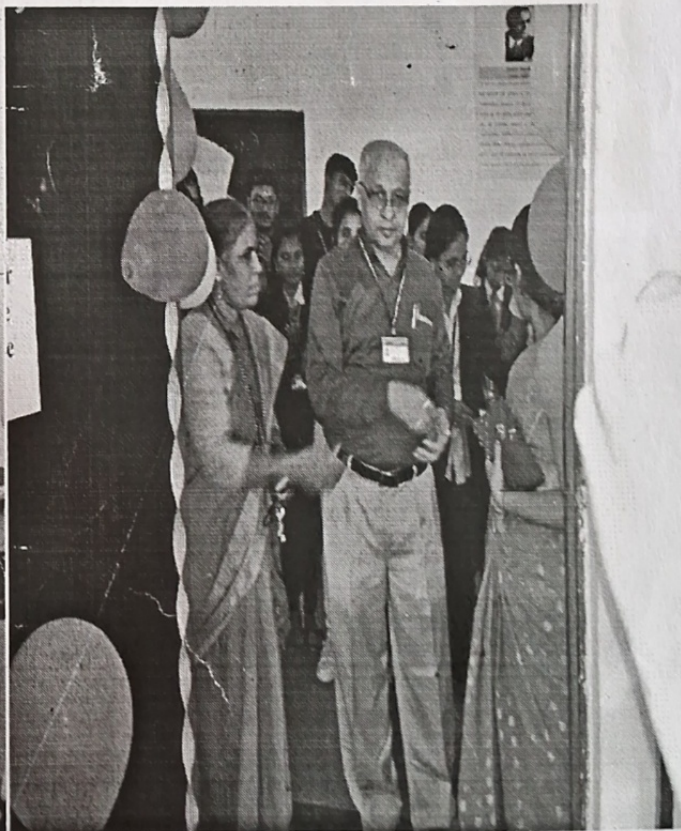
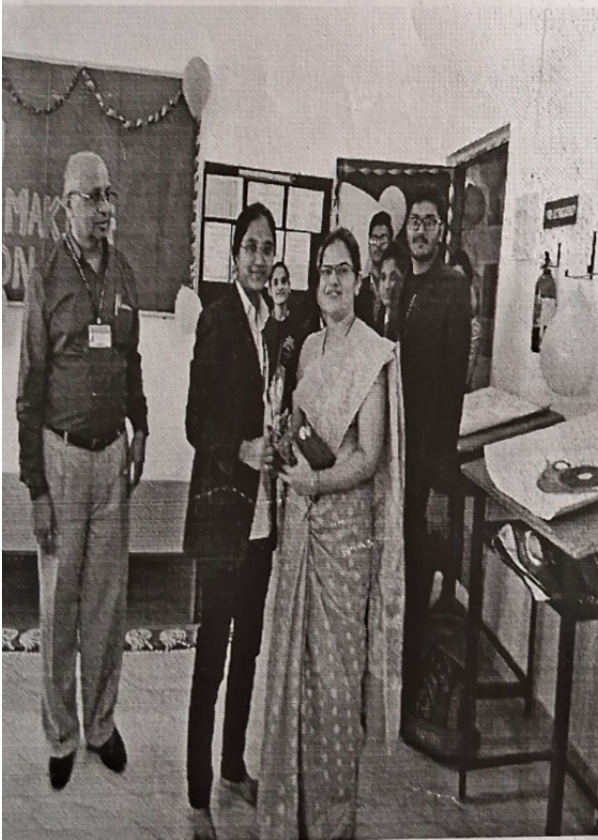
Principal
Dr. T.K. Nagraj
(BSIOTR)
PRINCIPAL

**JAYAWANT SHIKSHAN PRASARAK MANDALS'S
BHIVARABAI SAWANT INSTITUTE OF TECHNOLOGY AND
RESEARCH, WAGHOLI, PUNE**
Photos of Event:

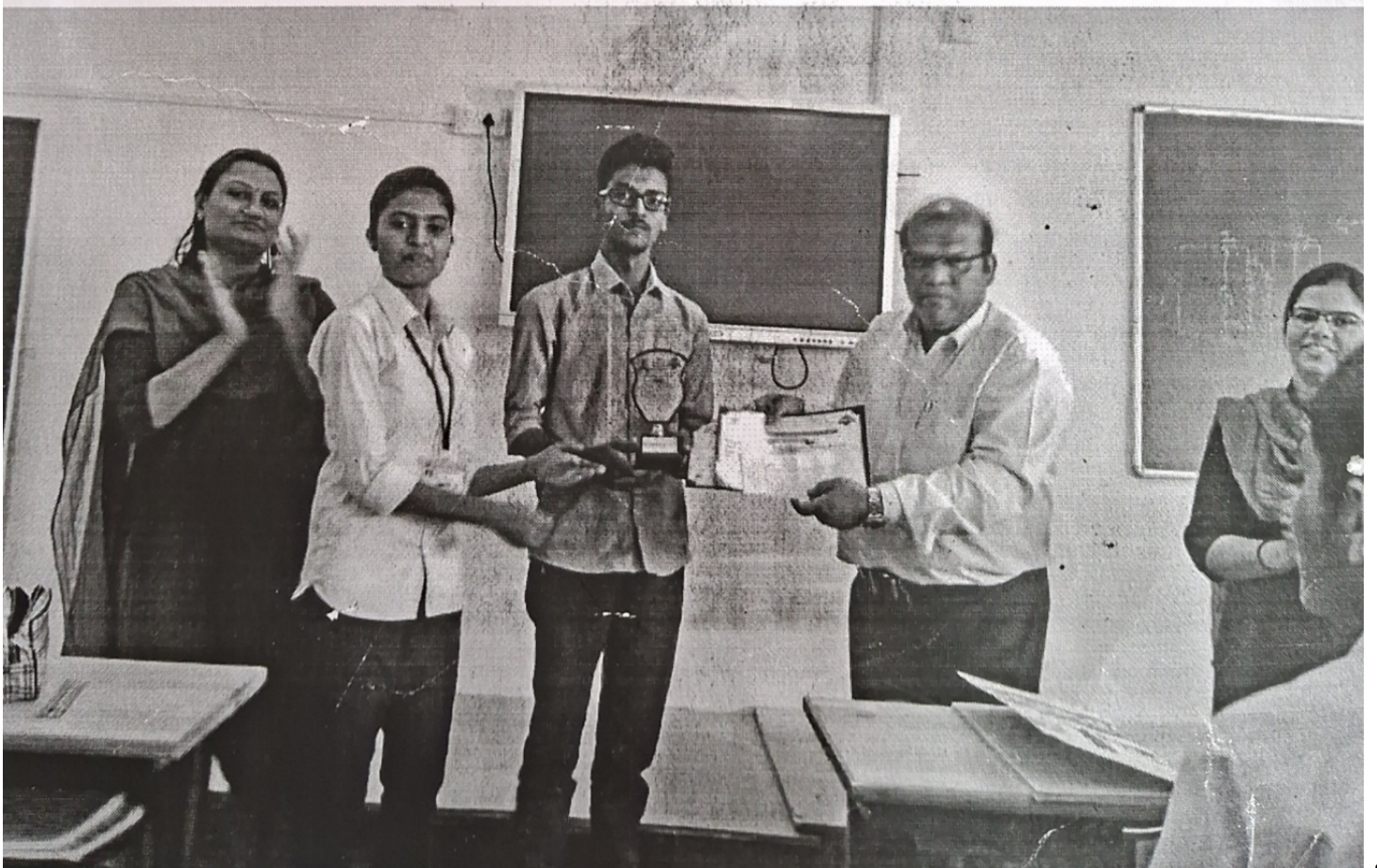

JAYAWANT SHIKSHAN PRASARAK MANDALS'S
BHIVARABAI SAWANT INSTITUTE OF TECHNOLOGY AND
RESEARCH, WAGHOLI, PUNE



**JAYAWANT SHIKSHAN PRASARAK MANDALS'S
BHIVARABAI SAWANT INSTITUTE OF TECHNOLOGY AND
RESEARCH, WAGHOLI, PUNE**

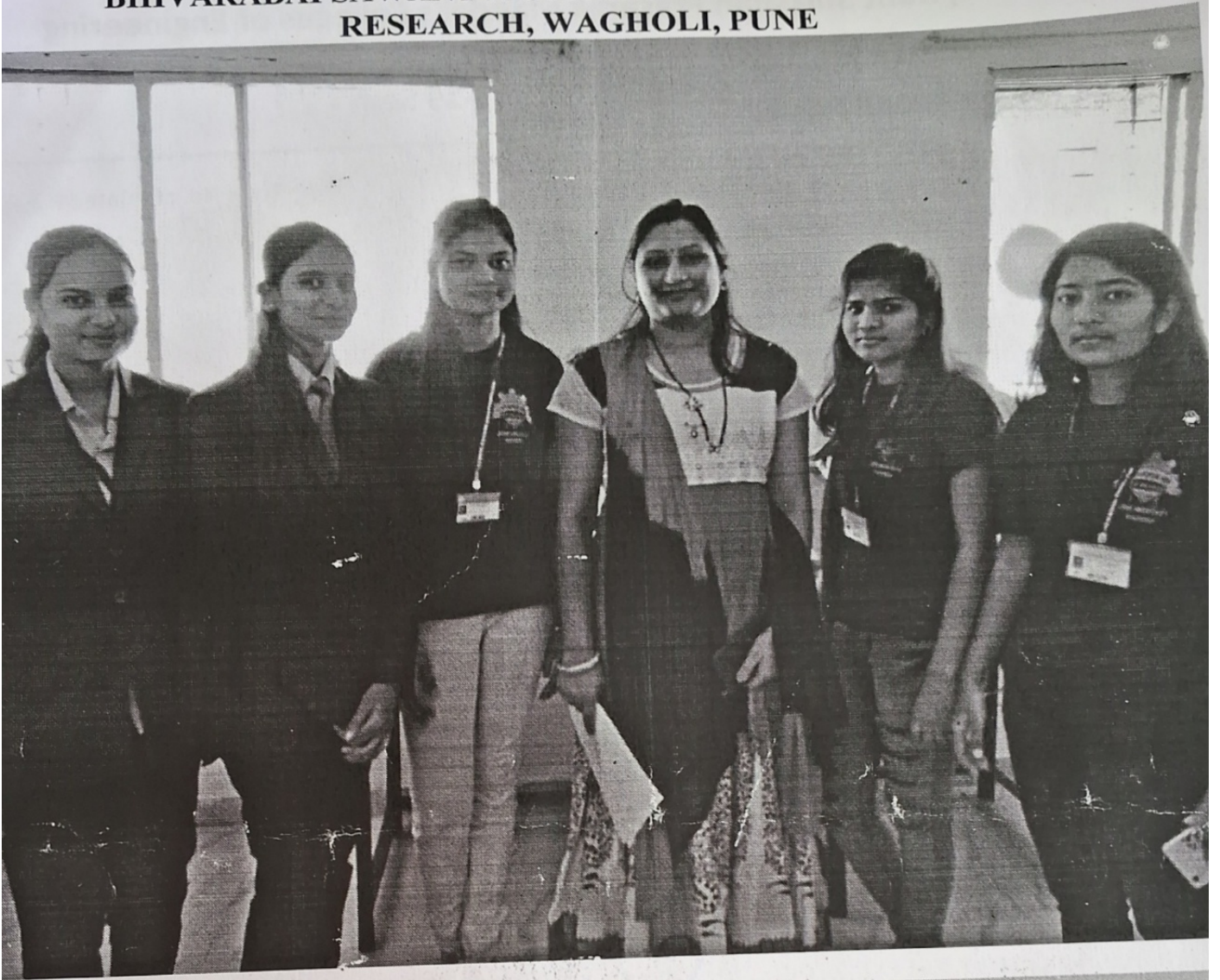

JAYAWANT SHIKSHAN PRASARAK MANDALS'S
BHIVARABAI SAWANT INSTITUTE OF TECHNOLOGY AND
RESEARCH, WAGHOLI, PUNE

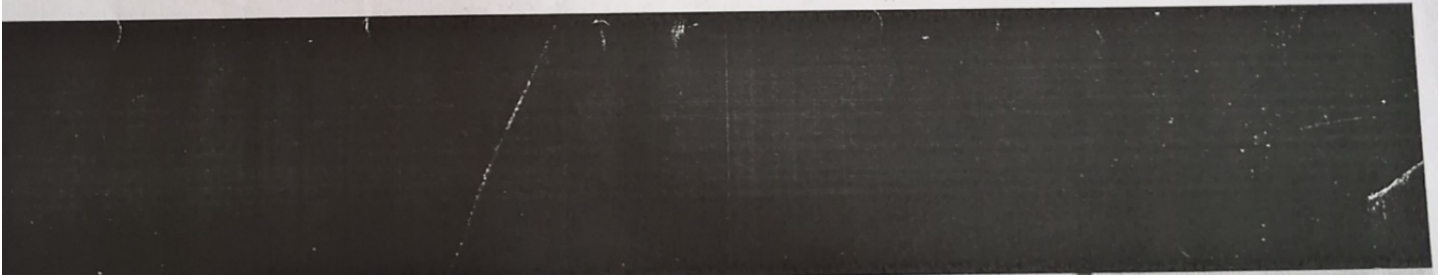

JSPM's
BHIVARABAI SAWANT INSTITUTE OF TECHNOLOGY & RESEARCH,
Wagholi, Pune 412207



NOTICE

Date-21/11/2019

This is for the information of all staff members of First Year Engineering Dept. of our institute that, an event **POSTER EXHIBITION** will be organized by our FE Dept. on **Saturday, 23rd November 2019** At **11:30 am** at 408, Drawing Hall, BSIOTR.

For this event the duties and responsibilities of teaching and non-teaching staff are as Follows:

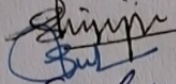
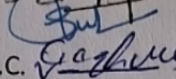
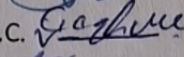
1) Internal discipline and arrangement inside drawing hall

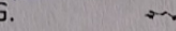
- i) Prof. Shimpi P.D. 
- ii) Prof. Awate S.S. 
- iii) Prof. Waghule S.C. 
- iv) Prof. Mane S.L. 
- v) Prof. Shrigan M.G. 

2) Decoration inside & outside of Drawing Hall (Rangoli, Banner, Board writing, Ribbon cutting arrangement)

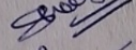
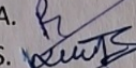
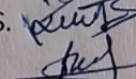
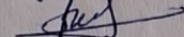
- i) Prof. Dhange W.S. 
- ii) Prof. Mahajan R.A. 
- iii) Mrs. Kumbhar I.S. 
- iv) Mrs. Thorat R.P. 

3) Format preparation

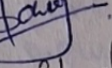
- i) Prof. Godase S.S. 
- ii) Mr. Shinde S.A. 

4) Accompany Judges panel

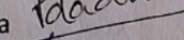
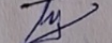
- i) Dr. Prafulla Sharma 
- ii) Prof. Godase S.S. 

5) Cleaning & Helping Assistance

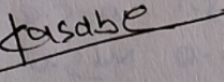
- i) Mr. Kishor Kasbe 

kindly take note of this.

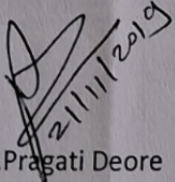
Dr. Pragati Deore
Exhibition Co-ordinator

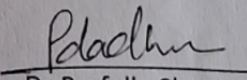
Dr. Prafulla Sharma
H.O.D. FE Dept

**JSPM's
Bhivarabai Sawant Institute
of Technology & Research,
Wagholi, Pune**

**Invites you to
visit an Art show**

**POSTER
EXHIBITION**

Featuring artwork created by
our beloved students of First
Year Engineering Department

Welcome your arrival

On

23rd - NOV-2019

At

11:30 AM

Venue

408, Drawing Hall

BSIOTR

With regards

Dr. Prafulla Sharma

H.O.D FE DEPT

Dr. Pragati Deore

Exhibition Co-ordinator

Event Title : POSTER EXHIBITION OF AC-ES
FE(BSIOTR, Pune)SEM-I-2019-20

Photograph of the event: “**POSTER EXHIBITION OF ENVIRONMENTAL STUDIES**”

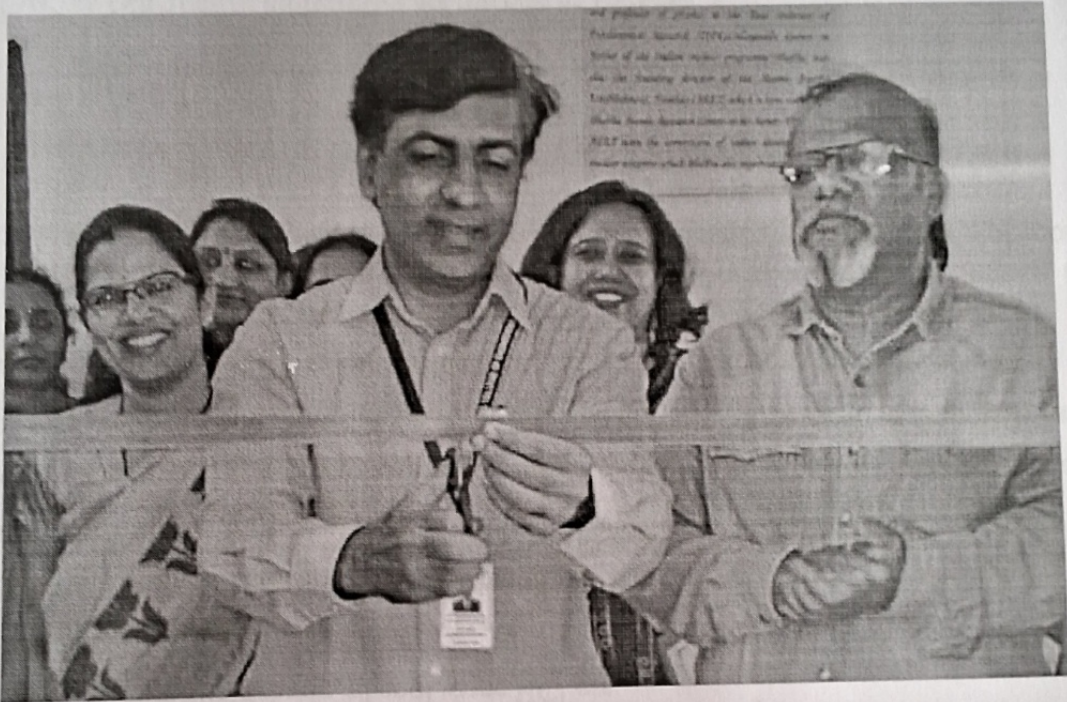

Poster Exhibition event ribbon cutting ceremony by **Hon’ble Principal Dr. T.K.Nagaraj, Prof. Javed Kadegaonkar, Dr.Prafulla Sharma**

First Year Engineering Dept. has organized Poster Exhibition event for first year students under the activity for audit course Environmental studies for the year 2019-20, SEM-I on 23/11/2019 at 11:30am. This event was inaugurated by Hon’ble Principal Dr. T.K.Nararaj as a chief guest, alongwith Judges panel of **Prof. Javed Kadegaonkar,ICOER** and **Prof. Ankita Sharma, Dept of IT,BSIOTR** and **Dr.Prafulla Sharma, HOD, Dept.of FE** with

ribbon cutting ceremony in presence of first year students and faculties.

After entering the Exhibition hall everybody was amused to see beautiful poster creations by first year students of divisions A,B,C and D. Students had shown enthusiastic response in environmental as well as social awareness, nature awareness topics and shown tremendous interest in preparing beautiful posters by their creative and innovative ideas. Even very experienced Judges panel also surprised while evaluating each and every poster. It became a challenging task for them to observe any six best posters. Still they analysed and appreciated skills and performances of all participants. At the end Judges announced six posters as rankers.

First winner group was (SAMIKSHA PHAND, NANDINI GAVHANE & SNEHAL TELORE group), second winner was (PURVA AWHALE, SHRADHA AWHALE & RAJASHREE GOTE group) and third winner was (PRANAV KHULPE, TANMAY BODAKHE & BALAJI PAWAR group), fourth winner was (POOJA PAL, DNYANESHWARI JOGDAND & SONI SALONI group), fifth winner was (GARGI DESHMUKH & SANJANA CHAWADIMANI group), sixth winner was (DIKSHA SHELKE & NILAM GAVHANE group).

This event was concluded with Prize distribution to the winners followed by votes of thanks given by Dr. Pragati Deore, Poster Exhibition Coordinator. Principal Dr. Nagaraj and F.E. Dept. HOD Dr. Prafulla Sharma and judges' panel appreciated & congratulated to the team work & fruitful efforts of organizers, faculty & students for taking united efforts to make this exhibition successful and informative for all.

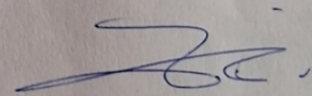



First year students with Chief Guest Dr.Nagaraj



Student presentation in front of Principal Sir



Student presentation in front of
HOD, Judges and coordinator



Winners of the event
At prize distribution ceremony

Pragati Deore
Exhibition
Coordinator

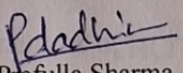
Dr. Prafulla Sharma
HOD-FE
HOD
General Science Department
J.S.P.M.'s Bhivarabai Sawant Institute of
Technology & Research
Wagholi Pune 412 207

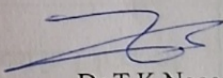
Dr. T.K. Nagaraj
Principal
PRINCIPAL
Bhivarabai Sawant Institute Of Technology & R
Wagholi, Pune- 412207.

Event Title: National Science Day (Online Mode)

Organized by

FE(BSIOTR, Pune)

Poster of the event: The details of the Program communicated through the WhatsApp Groups of each class.



Celebration of National Science Day

Day and Date: Monday, 01/03/2021

Time: 12:30pm

In 1928 an Indian Scientist Sir Chandrasekhara Venkata Raman discovered a phenomenon known as Raman Effect and for his remarkable discovery in 1930 he got Nobel Prize, which was the first Nobel Prize in India in the field of Science and to mark this discovery every year on 28th February National Science Day is celebrated.

As a part of the same First Year Engineering Dept. organized Various Competitions like Elocution, Essay Writing and poster making Competitions for first year Engineering Students on 01/03/2021 at 12:30pm. The programme was graced by the presence of **Hon'ble Principal Dr. T.K.Nararaj** as a chief guest, HOD of F.E Prof.Swati Godse and all Staff members of FE. All these three competitions are conducted division-wise and then final winners are decided by the judges.

The Elocution Competition was conducted on the topic "Science for People and People for Science". There were 12 students participated in this competition and winners of this event are Deshmukh Onkar (First), Rajkule Mrunali (Second) & Khatode Ashish (Third).

The Competition was Essay Writing Competition on the topic "Contribution of Dr.C.V.Raman to Science & Technology". Total 45 students were participated in this activity and winners are Tamhane Vaishnavi (First), Bute Akankhsa (second) and Aware Pooja (Third).

The third activity was Poster making Competition on the topic "Science and Technology". In this event total 29 students were actively participated and shown their hidden talents. The winners of this competition are Mane Nikita (First), Sah Ritesh (Second), Tambe Rutuja (third). All these competitions are judged by GFM of respective batches, Senior faculty member Prof.M.G.Shrigan and HOD Prof.Swati Godse. The HOD and **Hon'ble Principal Dr. T.K.Nararaj** congratulated to all winners and participants.

The programme ended with vote of thanks on behalf of the Institute by Prof.Sheetal Mane. All students along with FE Staff members attended this programme. Principal, Dean and HOD, F.E. congratulated faculty members of FE department and appreciated the efforts put by the Staff members in organizing such a Nice Competition. All faculty from F. E. Department worked hard for the success of the program. The event coordinated by Prof. M.G.Shrigan.

Poster Making Competition-Snaps:



Elocution and Essay Writing Competition-Snaps:

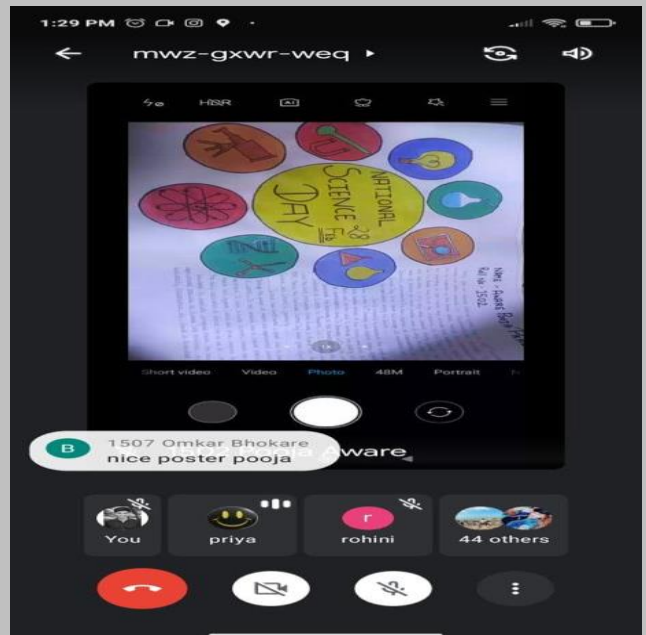
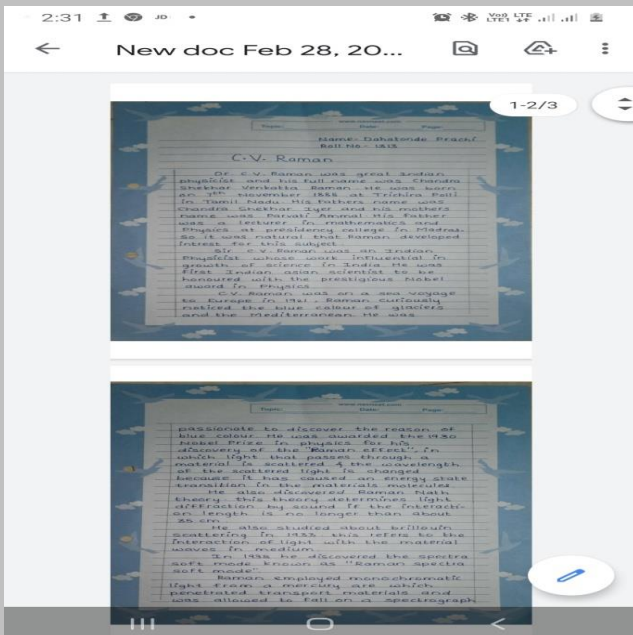

Signature

FE HOD
Dr. Swati Godse

Signature

Principal
Dr. T. K. Nagaraj



Jaywant Sawant Institute of Technology & Research

Bhivarabai Sawant Institute of Technology and Research Wagholi, PUNE



Event Title:Poster Making Competition

Organized by

FE(BSIOTR, Pune)

Day and Date: Friday 3rd June 2022

Venue: Seminar Hall

Time: 1:30pm.

The Poster Making Competition On the account of **World Environment day** was started with ribbon cutting ceremony by resource person Dr.T.K Nagaraj Principal, Dr. Gayatri Bhandari HOD-Computer Dept , Prof Vidya Jagtap HOD-IT Dept, Prof. Radha Shirbhate, Dr.Swati Godse HOD FE. Initially Prof.Shrigan M.G & Prof. Bhourgunde S.D gave brief introduction about the program. After that resource person observed all poster with their presentation and gave suggestions for improvement. In this competition total 287 Students have participated.

The winners are as follows:

Division	Winners Name
A	1) Chaitanya Thakor 2) Dhruv Patil 3) Sandeep Klakude
B	1) Anjali Nair 2) Shivani Shitole 3) Saniya walkikar
C	1)Abhineya Beduru 2) Harshali Madake
D	1)Venketeyash Jadhav 2) Sakshi Jagtap 3) Aryan Varma
E	1)Pallavi Kolkur 2)Adwaita Bhadre 3)Ratndeeep Salgare

The programme ended with vote of thanks on behalf of the Institute by Dr. Swati Godse . All students along with FE Staff members attended this programme. HOD of F.E. congratulated faculty members of FE department and appreciated the efforts put by the Staff members in organizing such a Nice event . All faculty from

FE Department worked hard for the success of the program. The event coordinated by Prof . Shrigan M.G ,Prof . Bhourgande S.D & Prof. Thombre A.A.





FE HOD
Dr. Swati Godse

Principal
Dr. T. K. Nagaraj



Poster Making Competition Report

NAME OF THE EVENT	<u>“Poster Making Competition”</u>
DATE	27 th January 2023
TIME	10:45 am to 3 p.m.
HOST	Department of First Year Engineering of JSPM’s BSIOTR,Wagholi,Pune.
TARGET AUDIENCE	FE faculties and First year engg. students
TOTAL ATTENDEES	334

Poster making Competition Objectives:

1. To create awareness about environment related issues and share information about it.
2. To acknowledge create aspects of student and trigger their thought process towards finding solution
3. To imbibe critical analysis and introspects on the issues .

PO attainment:PO3,PO7,PO12.

JSPMs Group of Institutes was established with a vision to satisfy the aspirations of youth force who want to lead nation towards prosperity through techno- economic development. So, keeping this vision in mind our Department of First Year Engineering organized “Poster Making Competition”on27th January 2023 at 10:45 am to 3 p.m. for awareness about environment related issues that is visually inclusive. The inauguration ceremony was auspiciously graced by Honorable Dr. T.K. Nagaraj (Principal, BSIOTR) along with Dr.Gayatri Bhandari(HOD Computer Dept.),Dr.Yogesh Angal(HOD E&TC Dept.),Dr.N.N. Ghuge (HOD,Electrical Dept.),Prof.Prabhuling Jatti(IQAC Head).

The competition was organized on following topics:

1. Local Polluted Site (Urban/Rural/Industrial/Agricultural)
2. Global Warming
3. Disaster Management (Natural disaster/Flood/Earthquake/Cyclones/Landslide)
4. Environment Assests / Environment Sustainability (River/Forest/Flora/Fauna)
5. Biodiversity
6. Environmental Impact Assessment

Hon. Mr.Rushiraj Sawant, Director, JSPM & TSSM Group of Institutes and Dr. S.V. Admane, Campus director JSPM Wagholi Campus has appreciated for successful conduction of this competition. Dr. T.K. Nagaraj, Principal BSIOTR, have supported us for this event. FE HoD and all faculties were present for this competition.

FE HOD
Dr. Swati Godse

Principal
Dr. T. K. Nagaraj

Co-ordinators
Prof. Priyanka Bhojar
Prof. Dnyaneshwar Magar
Prof. Raviraj Kapure
Prof. Vivek Mohite

1. Dr. T.K. Nagaraj (Principal, BSIOTR) and All departments HOD's with Participants.





Department of First Year Engineering Science
Report On
“ENGINEER’S DAY”
on 15/09/2023

Name of The Programme	1. Logo making Competition (Theme-FESA) 2. Poster Making Competition (Theme-Respective Branch-wise) 3. Best out of waste (Theme-Respective Branch-wise)
Date	15/09/2023 Friday
Mode	Offline
Organizer	Department of First Year Engineering Science of <i>Bhivarabai Sawant Institute of Technology & Research</i> Wagholi, Pune
Programme Convenor	Dr. Swati Godse, HOD (FE)
Programme Coordinator	Asst. Prof. Komal Dagwal (FE) Asst. Prof. Neha Holey (FE) Asst. Prof. Snehal Pachegaonkar (FE) Asst. Prof. Rani phulpagar (FE)
Participants	Div A - 27 Div B - 54 Div C - 34 Div D - 36 Div E - 59 Div F - 35 Div G - 43 Div H - 22
Outcome	1.Improvement in Technical knowledge and skills 2.Improve presentationskills 3.Students develop behaviors such as curiosity, initiative, and persistence that will help them engage with the world in productive ways
Aligned PO	PO 6 – Engineering and Society PO 7 - Environment and Sustainability PO9 - Individual and Team Work PO10-Communication PO12-Life-long Learning

First Year Engineering Department , BSIOTR organized three competitions viz., Logo making Competition, Poster Making Competition and Best out from West on the occasion of ENGINEER’S DAY for the FE students, on Saturday 15/09/2023. Event inauguration function started at 2.30 pm , Inaugurated by Dr T. K. Nagaraj, Principal, BSIOTR in presence of Dr Swati Godse, Head of Department First Year Engineering Science. After inauguration all the judges observes all the logos, posters and models and ask questions to participants one by one. All the judges appreciated the efforts taken by all the participants. This competition help to Improve presentation power and technical knowledge of their respective branches.

Principal Sir and HOD mam motivated all the students for actively participate in all the events conducted by the department . The session ended with the vote of thanks on behalf of all the students. All the students along with the all the faculties attended the programme.







List of Participants attach here by

Sr.No.	Name of Participants	Sr.No.	Name of Participants
1	Samiksha Kawade	9	Girish Patil
2	Ankita Khot	10	Samruddhi Gorde
3	Tamanna Ghadse	11	Anurag Shinde
4	Akhilesh Shelke	12	Nikhil Padsare
5	Bhakti Tour	13	Kuldeep Mane
6	Maske Rushikesh	14	Abhijit Khaire
7	Atharv Ingale	15	Khushi Dhakate
8	Vaishnavi dange	16	Rushab jain

Name of Winners

Sr. No.	Division	Name of Participants
1	D (1411)	Girish Patil
2	D (1408)	Nikhil Padsare
3	E (1514)	Samruddhi Gorde

Report Prepared By:

Prof D.V.Magar

Prof Komal Dagwal

The programme ended with vote of thanks by HOD Dr. Swati Godse.

We are very much thankful to our institute management and department for the encouragement to conduct such event. Also thankful to “**AICTE SPICES BSIOTR MANTHAN CLUB**” for their continuous support and encouragement to conduct event under **MANTHAN**.



FE HOD
Dr. Swati Godse



Principal
Dr. T. K. Nagaraj

**JSPM's Bhivarabai Sawant Institute of Technology & Research, Wagholi,
Pune (412207)**

**DEPARTMENT OF ELECTRICAL
ENGINEERING**

Energy Conservation measures by Electrical Engineering Department

In the department of Electrical Engineering for HOD Cabin & Smart Board separate Offline 1 KW off grid Solar power system is installed. Three Solar plates of 350 Watt each are mounted on rooftop. Cable is connected to solar inverter and back up is taken from battery. This back up supports 5 , 20 Watt LED bulbs, 2 Ceiling fans, 2 PCs, 2 Laser Printers and one Laptop without any break.

Also supply is given to Smart board which is installed in Smart Classroom so that even in case of power failure uninterrupted teaching is in process. Solar system generates on an average 12-13 Units per day. In PV Mode Solar Voltage is 30.4 V , PV Current is 10.4 A. In UPS mode Battery Voltage is 30.4 V , Output Voltage is 217 V. In two years 2610.947 KWH energy is saved. Pay back period of this system is 4 years.

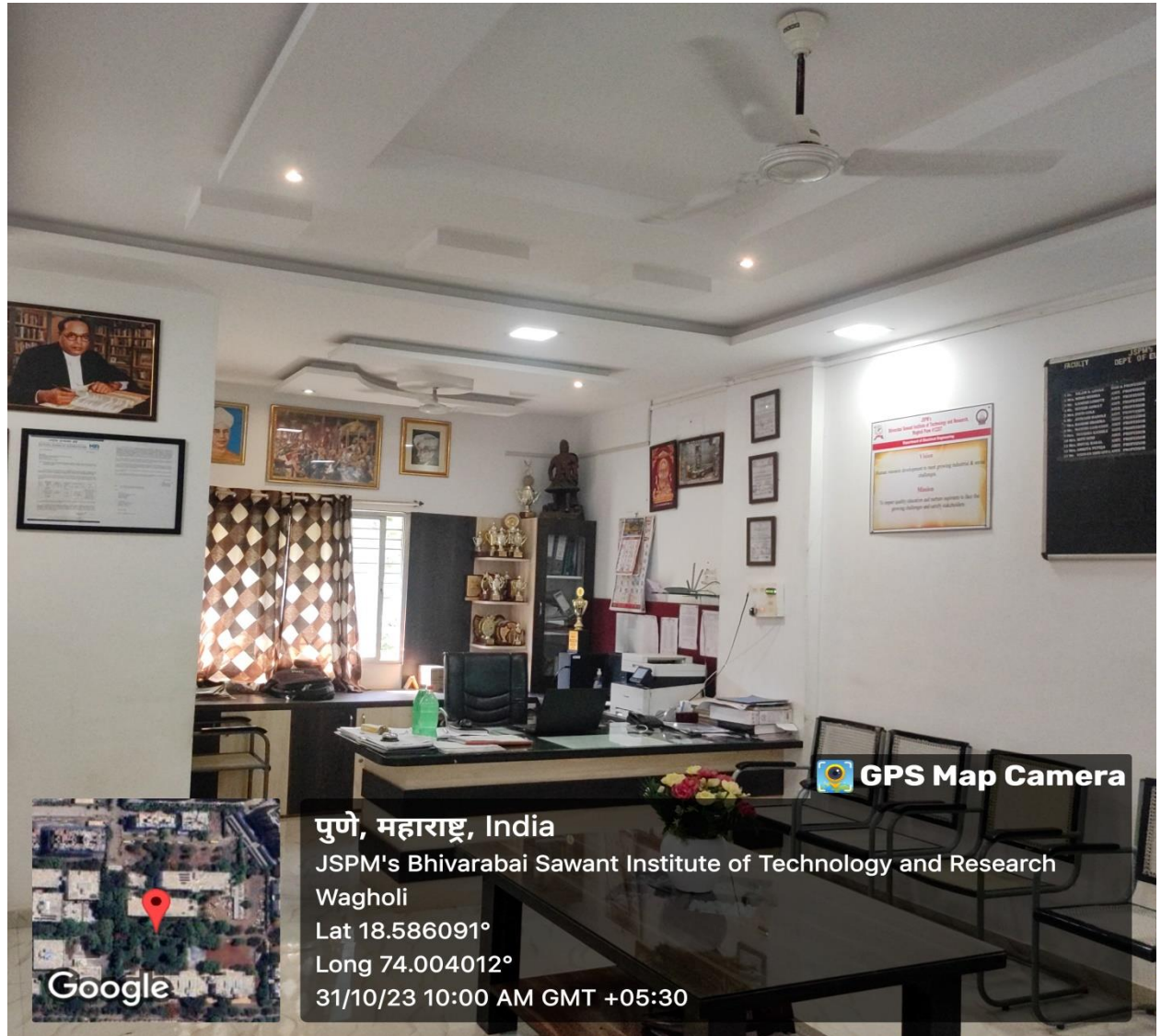



Google

GPS Map Camera

Kesnand, Maharashtra, India
JSPM College Rd, Wagholi, Kesnand, Maharashtra 412207, India
Lat 18.586074°
Long 74.004064°
31/10/23 10:10 AM GMT +05:30



Google

GPS Map Camera

पुणे, महाराष्ट्र, India
JSPM's Bhivarabai Sawant Institute of Technology and Research
Wagholi
Lat 18.586091°
Long 74.004012°
31/10/23 09:59 AM GMT +05:30

ENERGY CONSERVATION MEASURES :

- 1) “Switch Off Tube and Fans when not in use” such Instructions are displayed near switch boards.



- 2) Switching of Tubes which are located in corridor are controlled through a small circuit which is operated on the signal from motion sensor. In this circuit motion sensor detects presence of human being and switch on tube, as person disappears ie no motion is sensed by sensor supply of tube is disconnected.

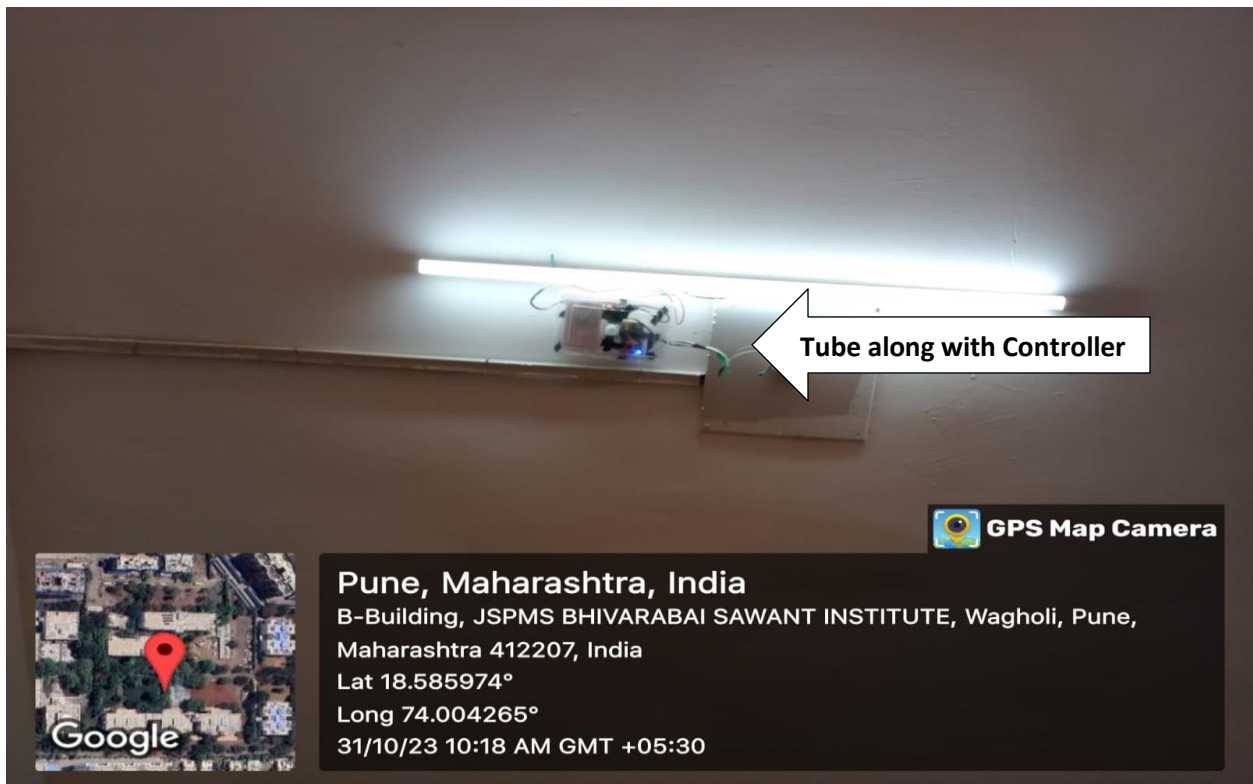
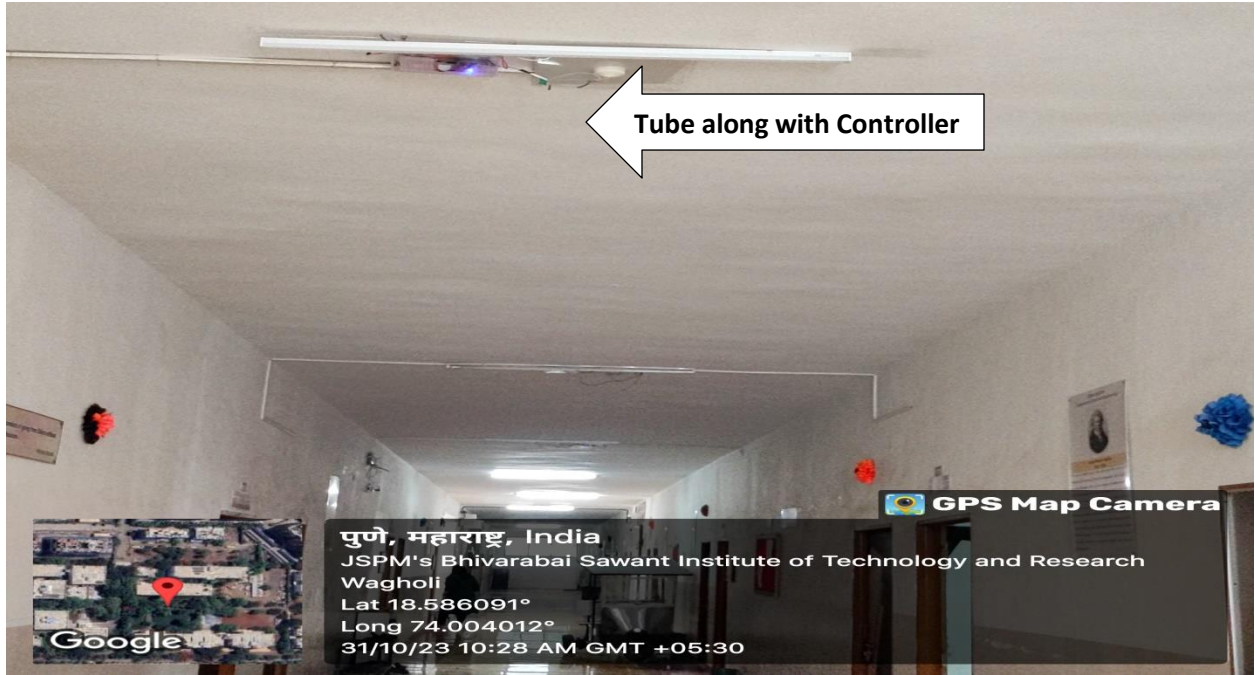

- 3) **Lab Automation** : In computer Lab pair of Tube and Fan is controlled by one controller circuit. Lab is divided into four parts. If students or faculty is working in one part and there is no any student or faculty in other three parts then it's a wastage of electricity as all fans and tubes are ON. So sensor sense the motion of human being and switch on particular fan and tube & fan / tube from remaining sections are OFF. Also even if after completion of work student or faculty leave the lab without switching OFF fan and tube, these are automatically OFF after stipulated predefined period as there is no any motion.



- 4) **Remote Switching:** In this case a remote controlled Arduino circuit is incorporated in the circuit which controls the supply of Fan, Tube in the faculty cabin. Suppose faculty left his cabin when supply is cut off and he forget to switch off control switch, when supply is restore, Fan Tube will be switched ON. So in this case faculty can operate switches of Fan and Tube even from remote location through his mobile app and switch off the tube and fan.

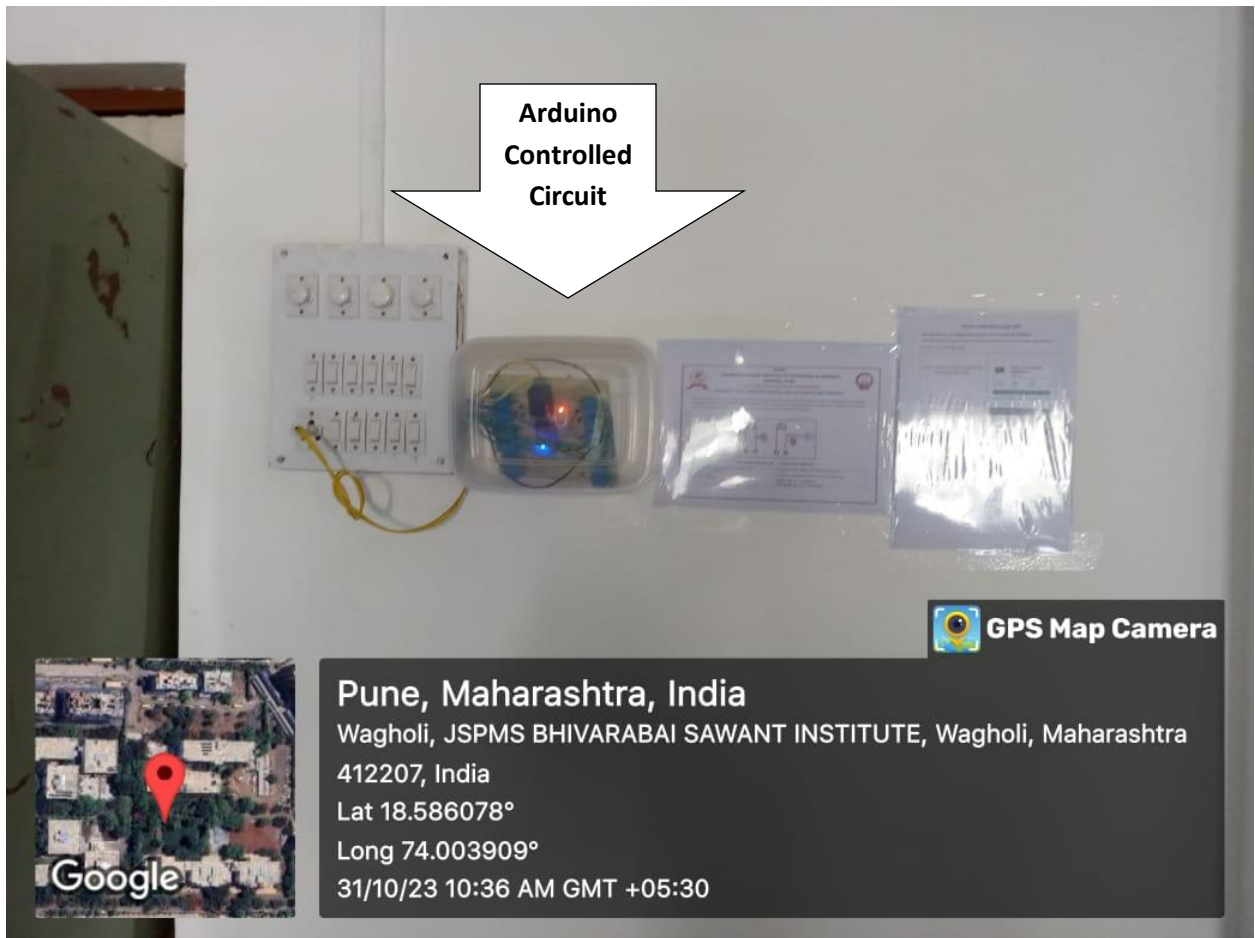

**JSPM's Bhivarabai Sawant Institute of Technology & Research, Wagholi,
Pune (412207)**

**DEPARTMENT OF INFORMATION
TECHNOLOGY ENGINEERING**



Prof. Dr. T. J. Sawant
B.E. (Elec.) PGDM, Ph.D
Founder Secretary

JAYAWANT SHIKSHAN PRASARAK MANDAL'S

Bhivarabai Sawant Institute of Technology & Research

(Approved by AICTE New Delhi, DTE Mumbai & Affiliated to Savitribai Phule Pune University)

Gat No. 719/1 & 2, Wagholi, Pune-Nagar Road, Pune-412207

Ph : 020-067335108, 65217050, 67335100

Telefax : 020-67335100

Website : www.jspm.edu.in / www.bsiootr.org

EN 6311 / CEGP-013100



Dr. T.K. Nagara
ME. (Civil Engg), Ph.D (Civil Engg)
LMSTE, LMGS, LMRC
LMISRAFT, LMIE

Principal

Institute Accredited by National Assessment and Accreditation Council (NAAC), Bengaluru

National Board of Accreditation (NBA), New Delhi. Accredited Programs:

Information Technology, Electronics and Telecommunication Engineering, Electrical Engineering

Report on Computer Lab Automation through Motion Sensor Technology

Introduction: In an era where technological advancements are rapidly transforming our daily lives, integrating automation into various aspects of our surroundings becomes imperative. This report explores the implementation of computer lab automation through the utilization of motion sensor technology, specifically Passive Infrared (PIR) sensors, relays, and microcontrollers. The primary goal is to enhance energy efficiency by activating tube lights and fans based on detected motion within the lab.

Components Used:

1. Passive Infrared (PIR) Sensor:

- PIR sensors detect infrared radiation emitted by objects in their field of view. These sensors are employed to capture the heat signatures of moving objects, such as individuals entering the computer lab.

2. Relay:

- Relays serve as switching devices that control the power supply to the tube lights and fans. In this setup, relays act as intermediaries between the microcontroller and the electrical appliances, allowing for remote control.

3. Microcontroller:

- A microcontroller, the brain of the system, processes signals from the PIR sensor and triggers the corresponding relays. Arduino or Raspberry Pi are common choices for this purpose due to their versatility and ease of programming.

Working Principle: The PIR sensor continuously monitors the computer lab for any movement. When a presence is detected, the sensor sends a signal to the microcontroller. The microcontroller, programmed to respond to these signals, activates the relays connected to the tube lights and fans. As a result, the lights and fans are turned on, creating a conducive environment for users. After a predefined period of inactivity, the microcontroller instructs the relays to switch off the lights and fans, contributing to energy conservation.



Vision: "To Satisfy the aspirations of youth force, who want to lead the nation towards prosperity through techno-economic development"

Mission: "To provide, nurture and maintain an environment of high academic excellence, research and entrepreneurship For all aspiring Students, which will prepare them to face global challenges maintaining high ethical and moral Standards"



Advantages:

1. **Energy Efficiency:** The system ensures lights and fans are only operational when needed, reducing unnecessary energy consumption.
2. **Cost Savings:** By automating the control of electrical appliances, the institution can experience cost savings on electricity bills.
3. **User Comfort:** The automation provides a seamless and comfortable user experience by eliminating the need for manual control.

Challenges and Considerations:

1. **False Positives:** PIR sensors may occasionally trigger false positives due to factors like rapid temperature changes or the presence of small animals. Fine-tuning the sensitivity of the sensor can mitigate this issue.
2. **Maintenance:** Regular maintenance and monitoring are essential to address any technical glitches or component failures.
3. **Integration with Existing Systems:** Compatibility with existing infrastructure and systems within the computer lab should be ensured during the implementation phase.

Conclusion: The integration of motion sensor technology into computer lab environments offers a promising avenue for enhancing energy efficiency and user experience. By utilizing PIR sensors, relays, and microcontrollers, institutions can contribute to sustainable practices while providing a technologically advanced and user-friendly workspace. As technology continues to evolve, the automation of such spaces will likely become more commonplace, further optimizing resource utilization.

Dr. Praveen Barapatre
HOD



JAYAWANT SHIKSHAN PRASARAK MANDAL'S Bhivarabai Sawant Institute of Technology & Research

(Approved by AICTE New Delhi, DTE Mumbai & Affiliated to Savitribai Phule Pune University)

Gat No. 719/1 & 2, Wagholi, Pune-Nagar Road, Pune-412207

Ph : 020-067335108, 65217050, 67335100

Telefax : 020-67335100

Website : www.jspm.edu.in / www.bsiotr.org

EN 6311 / CEGP-013100



Prof. Dr. T. J. Sawant
D.E. (Elec.) PGDM, Ph.D
Founder Secretary

Dr. T.K. Nagaraj
ME. (Civil Engg), Ph.D (Civil Engg)
LMISTE, LMIGS, LMIRC
LMISRMTT, LMIE
Principal

Institute Accredited by National Assessment and Accreditation Council (NAAC), Bengaluru
National Board of Accreditation (NBA), New Delhi. Accredited Programs:
Information Technology, Electronics and Telecommunication Engineering, Electrical Engineering

Images of Smart Laboratories

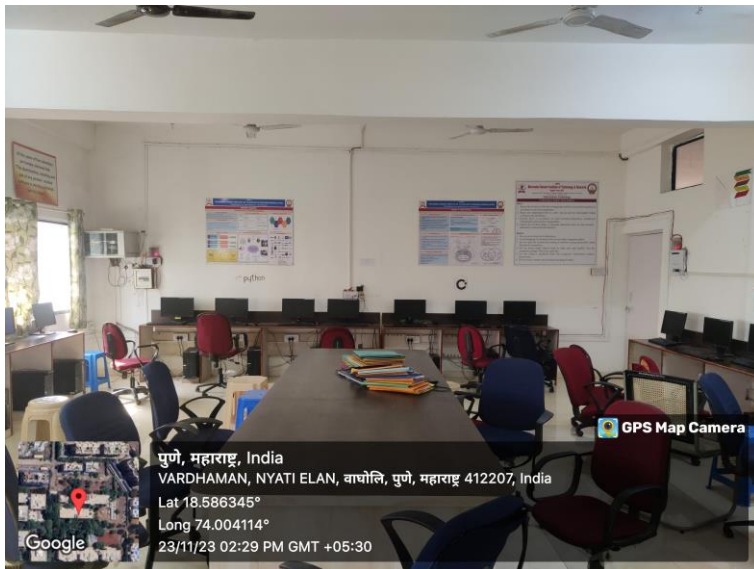

Dr. Praveen Barapatre
HOD



Vision: "To Satisfy the aspirations of youth force, who want to lead the nation towards prosperity through techno-economic development"

Mission: "To provide, nurture and maintain an environment of high academic excellence, research and entrepreneurship For all aspiring Students, which will prepare them to face global challenges maintaining high ethical and moral Standards"



**JSPM's Bhivarabai Sawant Institute of Technology & Research, Wagholi,
Pune (412207)**

**DEPARTMENT OF ELECTRONICS
AND TELECOMMUNICATION
ENGINEERING**



Bhivarabai Sawant Institute of Technology & Research

(Approved by AICTE New Delhi, DTE Mumbai & Affiliated to Savitribai Phule Pune University)

Gat No. 719/1 & 2, Wagholi, Pune-Nagar Road, Pune-412207

Ph : 020-067335108, 65217050, 67335100

Telefax : 020-67335100

Website : www.jspm.edu.in / www.bsiotr.org

[EN 6313] / [CEGP-013100]



Prof. Dr. T. J. Sawant
B.E. (Elec.) PGDM, Ph.D
Founder Secretary

Dr. T.K. Nagaraj
ME. (Civil Engg), Ph.D (Civil Engg)
LMISTE, LMIGS, LMIRC
LMISRMTT, LMIE
Principal

Institute Accredited by National Assessment and Accreditation Council (NAAC), Bengaluru

National Board of Accreditation (NBA), New Delhi. Accredited Programs:

Information Technology, Electronics and Telecommunication Engineering, Electrical Engineering

7.1.2 Initiatives Taken for Institutes for Alternate Sources of Energy and Energy Conservations Measures

Department of Electronics and Telecommunication Engineering

Sr. No.	Particulars	Cost(In Rs.)
1	Roof Top Solar System 10Kw Grid Connected Solar Power Plant, 32 Modules of 325wp(renewys), Structure HoT Dip galvanised with 86 Microns	6,50,000/-
2	To control the connected electrical appliances remotely to reduce energy wastage using IoT	1500

Dr. Y.S. Angal
H.O.D.(E&TC)

Dr. T. K. Nagaraj
Principal
S.P.M.'S Bhivarabai Sawant Institute of
Technology & Research
Wagholi, Pune- 412207



Vision: "To Satisfy the aspirations of youth force, who want to lead the nation towards prosperity through techno-economic development"

Mission: "To provide, nurture and maintain an environment of high academic excellence, research and entrepreneurship For all aspiring Students, which will prepare them to face global challenges maintaining high ethical and moral Standards"



सावित्रीबाई फुले पुणे विद्यापीठ (पूर्वीचे पुणे विद्यापीठ)

दूरध्वनी क्रमांक. :

०२०-२५६०१२६४

२५६०१२६५

ई-मेल: pldvp@unipune.ac.in



नियोजन व विकास विभाग,
गणेशखिंड, पुणे-४११००७.

संदर्भ : साफुपुवि/निववि/63

दिनांक : ३०/०१/२०१९

प्रति,

मा. प्राचार्य/संचालक,

सर्व संबंधित संलग्न महाविद्यालये/मान्यताप्राप्त परिसंस्था.

विषय: महाविद्यालय गुणवत्ता सुधार योजनेअंतर्गत बिगर आदिवासी व आदिवासी विभागातील संलग्न महाविद्यालये/मान्यताप्राप्त परिसंस्थाना शैक्षणिक वर्ष सन २०१८-१९ मध्ये सौर ऊर्जा उपकरण खरेदीसाठी अर्थसहाय्य मंजूरीबाबत.

महोदय/महोदया,

महाविद्यालय गुणवत्ता सुधार योजनेअंतर्गत बिगर आदिवासी व आदिवासी विभागातील संलग्न महाविद्यालय/मान्यताप्राप्त परिसंस्था यांनी शैक्षणिक वर्ष सन २०१८-१९ मध्ये ऑनलाईन पध्दतीने सौर ऊर्जा उपकरणासाठी मार्गदर्शकतत्वांस अनुसरून प्रस्ताव सादर केलेले आहेत. अशा महाविद्यालयांना/परिसंस्थाना त्यांच्या नावापुढे नमूद केलेल्या रकमेस सोबत जोडलेल्या मार्गदर्शकतत्वांस अनुसरून विद्यापीठ नियमाच्या अधिन राहून सोबत जोडलेल्या तक्त्यात नमूद केल्यानुसार त्रुटीची पूर्तता करण्याच्या अटीवर अर्थसहाय्य मंजूरी देण्यात येत आहे. अर्थसहाय्य मंजूरीची विद्यापीठ संकेतस्थळावरील यादी हीच मंजूरी समजवण्यात यावी. अर्थसहाय्य मंजूरीची स्वतंत्र पत्रे पाठविण्यात येणार नाहीत.

आपल्या महाविद्यालय/परिसंस्थेस जरी वरीलप्रमाणे अर्थसहाय्य मंजूरी देण्यात आली असली तरी प्रत्यक्ष कार्यवाही पुढील बाबींची पूर्तता झाल्यानंतरच केली जाईल.

१. महाविद्यालये/परिसंस्थेस सौर ऊर्जा उपकरणे बसविण्याकरिता सोबत जोडलेल्या मार्गदर्शकतत्वांचा त्यासोबतच्या नियमावलीचा अवलंब करून कार्यवाही करावी. (सोबत मार्गदर्शकतत्वे / नियमावली)
२. महाविद्यालय/परिसंस्थेस सौर ऊर्जा उपकरणे बसविण्याकरिता भेटी, प्रत्यक्ष पाहणी अहवाल पडताळणी इत्यादीसाठी रू. ३,०००/- मा. वित्त व लेखाधिकारी, सावित्रीबाई फुले पुणे विद्यापीठ, पुणे-७ यांचे नावाने एम.एल. सी. कोड नं. ११०३७ (Charges for Proposal of Solar Energy Equipment) कोड नं. ९४ चलन नंबर ५४ ने ऑनलाईन जमा करणे आवश्यक आहे.
३. सौर ऊर्जा उपकरणे बसविल्यानंतर महाविद्यालय/परिसंस्थेने विद्यापीठाच्या आंतरशास्त्र ऊर्जा प्रणाली विभागास सौर ऊर्जा उपकरणांची अंतिम पाहणी करण्याबाबत लेखी कळवावे. त्या

३. सौर ऊर्जा उपकरणे बसविल्यानंतर महाविद्यालय/परिसंस्थेने विद्यापीठाच्या आंतरशास्त्र ऊर्जा प्रणाली विभागास सौर ऊर्जा उपकरणांची अंतिम पहाणी करण्याबाबत लेखी कळवावे. त्या अनुषंगाने आंतरशास्त्र ऊर्जा प्रणाली विभागाकडून पुढील कार्यवाही सुरू होईल. यासाठी मा. संचालक, आंतरशास्त्र ऊर्जा प्रणाली विभाग यांना दूरध्वनी क्रमांक ०२०-२५६०१४१५/२५६९५२१०, (१) डॉ. संदेश जाडकर - भ्रमणध्वनी क्रमांक ९७६५३६११२४, (२) डॉ. आदिनाथ फुदे - भ्रमणध्वनी क्रमांक ८२०८८३४६३३ वर संपर्क करावा. आंतरशास्त्र ऊर्जा प्रणाली विभागाकडून काम यशस्वीरित्या पूर्ण झाल्याचा अहवाल प्राप्त झाल्यानंतरच अंतिम अर्थसहाय्य रक्कम अदा करणेबाबत विचार केला जाईल.
४. महाविद्यालये/परिसंस्थेस सौर ऊर्जा उपकरणे बसविण्याकरिता सोबत जोडलेल्या अधिकृत पुरवठादार यादीमधील पुरवठादारांकडून शासनाने खरेदी प्रक्रिये संदर्भात विहित केलेल्या नियमा प्रमाणे निविदा मंजूर करून त्यावर प्राचार्यांची सही व शिक्का घेवून त्यानंतरच पुढील कार्यवाही करावी.
५. सोबत जोडलेल्या 'अ' 'ब' व 'क' श्रेणी मधील अधिकृत पुरवठादारांच्या यादीमधील मंजूर पुरवठादारांशीच संपर्क साधून सौर ऊर्जा उपकरणे बसविणे आवश्यक आहे. अधिकृत पुरवठादारांवरून इतर पुरवठाधारांकडून उपकरणे बसविल्यास उचल रक्कम व्याजासह विद्यापीठास परत करावी लागेल याची कृपया नोंद घ्यावी. (सोबत अधिकृत पुरवठादारांची यादी)
६. सौर ऊर्जा उपकरणे बसविण्याकरिता उचल रक्कम महाविद्यालये/परिसंस्थेच्या खात्यावर NEFT द्वारे अदा करण्यात येणार असल्याने महाविद्यालये/परिसंस्थेने विद्यापीठाच्या संकेतस्थळावर लॉगिन करून खालील नमूद केलेली माहिती ऑनलाईन पध्दतीने भरावी व त्याची हार्ड कॉपी व महाविद्यालये/ परिसंस्थेच्या बँक खात्याच्या धनादेशाची स्कॅन कॉपी त्यासोबत जोडून उचल रक्कम मागणी विनंती अर्ज व हमीपत्रासह (सोबत नमूना) नियोजन व विकास विभागामार्फत वित्त व लेखा विभागास दोन प्रतीमध्ये सादर करावी. त्यानंतर उचल रक्कम देण्याबाबतची कार्यवाही करण्यात येईल.
 १. महाविद्यालये/परिसंस्थेचे नाव (महाविद्यालये/संस्थेच्या बँक पासबुकावरील नोंदीनुसार)
 २. बँक खाते क्रमांक
 ३. बँक खात्याचा प्रकार : चालू / बचत
 ४. आयएफएससी कोड
 ५. बँकेच्या शाखेचे नाव
६. महाविद्यालये/परिसंस्थेची इमारत/जागा स्वतःची अथवा दीर्घ मुदतीच्या (कमीत कमी २५ वर्षे) भाडेकरारावर आहे यासंबंधीचे हमीपत्र संबंधित महाविद्यालये/परिसंस्थेस संस्थेच्या सचिव किंवा अध्यक्ष व प्राचार्य/संचालक यांच्या संयुक्त स्वाक्षरीने सादर करावे लागेल.
७. ज्या महाविद्यालये/परिसंस्थेने बांधकामासाठी आर्थिक वर्ष २०१६-१७ पूर्वी उचल रक्कम घेतलेली असेल आणि मार्गदर्शकतत्वांप्रमाणे दोन वर्षात बांधकाम पूर्ण केलेले नसेल किंवा बांधकामपूर्णत्वाचे अंतिम हिशेब सादर केलेले नाहीत अशी सर्व महाविद्यालये/परिसंस्था सौर ऊर्जा उपकरणांच्या अर्थसहाय्यास अपात्र राहतील.
८. महाविद्यालये/परिसंस्थेने सादर केलेल्या प्रस्तावात नमूद केलेली माहिती खोटी/दिशाभूल करणारी असल्याचे निदर्शनास आल्यास अथवा मार्गदर्शकतत्वांचे तंतोतंत पालन न केल्यास

सदरील अर्थसहाय्य रद्द करण्याचे अधिकार विद्यापीठ कार्यालयाकडे राखून ठेवण्यात आलेले आहेत.

९. यापूर्वी बांधकाम शिर्षकांतर्गत मंजूर केलेल्या बांधकामासाठी उचल रक्कम घेऊनही, बांधकामाचे अंतिम हिशेब आतापर्यंत सादर केलेले नसतील. अशा संबंधित महाविद्यालय/परिसंस्थेस सौर ऊर्जा उपकरणे बसविण्याकरिता मंजूरी दिली जाणार नाही.
१०. सौर ऊर्जा उपकरणे बसविल्यानंतरची सर्व जबाबदारी, उदा. देखभाल व दुरुस्ती इत्यादी संबंधित महाविद्यालये/संस्थेची राहिल.
११. विद्यापीठ अधिकार मंडळाने वेळोवेळी घेतलेले निर्णय व नियमातील बदल सर्व संबंधित महाविद्यालय/परिसंस्थेवर बंधनकारक राहतील.
१२. ज्या महाविद्यालय/परिसंस्थानी All India Survey of Higher Education (AISHE) सन २०१८-१९ ची माहिती अद्याप भरलेली नाही अशा महाविद्यालय/परिसंस्थानी गुणवत्ता सुधार योजनेअंतर्गत अर्थसहाय्यासाठी सादर केलेल्या प्रस्तावांना उपरोक्त माहिती भरल्याचे ना-हरकत प्रमाणपत्र सादर केल्यानंतरच अर्थसहाय्य उचल रक्कम अदा करण्याबाबत विचार करण्यात येईल.

कळावे,

उपकुलसचिव
नियोजन व विकास विभाग

सोबत: वरीलप्रमाणे.

Financial Assistance Granted under QIP for Rooftop Solar System 2018-19

Sr. No.	Name & Address Of College/Inst.	Name Of Construction	Proposed Builtup Area	Previous Amount Sanctioned for Construction	Affiliated to UoP	Principal/ Director Approved/ Not Approved	Net Amount Required (Rs.)	Sanctioned Amount (Rs.)	Remarks
1	(CRS181209001) [CEDP012090] Abhinav Education Society's College of Education Addr: Ambegaon Tal: Haweli(excluding Corporation Area) Dist: Pune, Pincode: 411046	Construction of Rooftop Solar System	12500	500000.00	Yes	Yes-Permanent	708750.00	500000	OK
2	(CRS181316001) [IMMP013160] Institute of Management & Research. Addr: At Post Narhe Tal: Haweli(excluding Corporation Area) Dist: Pune, Pincode: 411041	Construction of Rooftop Solar System	6000	500000.00	Yes	Yes-Permanent	735000.00	500000	OK
3	(CRS181168006) [CAAP011680] DR D. Y. Patil Art's ,Commerce and Science College Addr: Sarve No 27Near Lokmanya HospitalNigdi Pradhikaran AkurdiPune Tal: Pimpri Chinchwad (corporation Area) Dist: Pune, Pincode: 411044	Hybrid Solar System	4275SQFT /7.5KVA	0.00	Yes	Yes-Permanent	720000.00	500000	OK

25	(CRS181273002) [IMMP012730] Kautilya Institute of Management and research Addr: Wagholi Pune Survey No 720-1 and 2 Tal: Haweli(excluding Corporation Area) Dist: Pune, Pincode: 412207	jspm kautilya Institute building top area	500 SQFT/9KV A	0.00	Yes	Yes-Permanent	500000.00	500000	OK
26	(CRS181349001) [CPHP013490] JSPM's Charak College of Pharmacy and Research Addr: Wagholi Pune Nagar Road Pune Tal: Haweli(excluding Corporation Area) Dist: Pune, Pincode: 412207	SOLAR SYSTEM	5000SQFT /9KVA	0.00	Yes	Yes-Permanent	500000.00	500000	OK
27	(CRS181258001) [CEGP012580] IMPERIAL COLLEGE OF ENGINEERING AND RESEARCH Addr: Pune Nagar Road Wagholi Pune Tal: Haweli(excluding Corporation Area) Dist: Pune, Pincode: 412207	Grid Tided	2000SQFT		0 Yes	Yes-Permanent	650000.00	500000	OK
28	(CRS181310001) [CEGP013100] Bhivarabai Sawant Institute of Technology and research Addr: Survey no 720 Pune Nagar road Tal: Haweli(excluding Corporation Area) Dist: Pune, Pincode: 412207	Agni Solar Systems Pvt. Ltd. 702 Onyx, North Main Road, Koregaon Park, Pune 411001 India	1100/10KV A	0.00	Yes	Yes-Permanent	600000.00	500000	OK



Savitribai Phule Pune University Planning And Development

Applications for financial assistance for Construction of Rooftop Solar System during the financial year 2018-2019

1.(a)	Name of the College/ Institute	: Bhivarabai Sawant Institute of Technology and research
(b)	Address in Details	: Survey no 720 Pune Nagar road Ta: Haweli(excluding Corporation Area) Dist: Pune Pincode: 412207
(c)	Telephone No.	: 02067335108
(d)	Email	: principalbsiotr@gmail.com
(e)	District	: PUNE
2.	Affiliated to Savitribai Phule Pune University	: Yes (Please attach Affiliation letter Copy)
3.	Name of the Principai/Director	: Nagaraj Kalyanappa Timalapur
	Mobile No:	: 9890678508
	Principal/Director Approved?	: Yes-Permanent (If Yes , Please attach approval Copy)
4.	Whether accredited by NAAC/NBA	: (If Yes, Please attach Copy)
5.	Whether AISHE DCF-II & M.I.S Information Uploaded :	: Yes-C-42056-2017-2017 (If 'Yes', Please attach Copy)
6.	Annual Report Information Given to University (Pervious Academic Year 2017-18)	: Yes (If Yes, attach copy of acknowledgement)
7.	Last Year Q.I.P. Sanctioned Grant Utilized	: Yes (If ,'No' Please attach Letter of Clarification)
8.	University All types of contribution i.e. Student Welfare Fund,Sports,AdmissionSection Prorata, Affiliation fee, etc. paid by college/Institutes	: Yes (If Yes, Please attach Copy)
9.	Is the College/Institute in Tribal Area?	: No (If 'Yes',Please attach Copy of Tribal area college certificate of concern authority)
10.	Proposed Rooftop Area (Sq.Ft)	: 1100/10KVA
(a)	P V Type of system & kw	: Grid-Tided
(b)	Estimated Cost Rs.	: 800000.00
(c)	Net amount required Rs.	: 600000.0000
11.	Is the College declared fit to receive grants under section 12(B) of UGC Act.	: No (If Yes, Please attach Copy)
12.	Details of Pervious sanctioned grant by University for Construction/Civil work (Please attach Copy of Sanction Letter)	
Year of Sanction (Date & Letter No.)		Amount
01/01/2000 00		NA 0.00



PRINCIPAL
S.P.M.'S Bhivarabai Sawant Institute of
Technology & Research
Wagholi, Pune- 412207
Tuesday, August 21, 2018 1:27 PM



CRS181310001



Annexure-2

Savitribai Phule Pune University

Planning And Development

13.	Any other information	:	We proposed to develop solar System for B4 Building of our Institute. It should be useful for carrying out academic activities like Practicals and Lectures. It will be useful as non conventional Energy source. It will be helpful to reduce electricity consumption.	(annex separate sh
-----	-----------------------	---	---	--------------------

2
Signature & Seal of the
Secretary Of Institute/Society

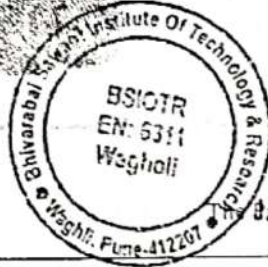

21/8/18
Signature & Seal of
Principal

S.P.M.S. Shivraj Institute of
Technology & Research
Waghari, Pune-412207

For Office Use Only :		2018-2019
प्राचार्य/ संचालकांचे मान्यतेचे पत्र		
वार्षिक अहवाल सादर केल्याची पोहोच प्रत		
संलग्नता/नुतनीकरण शुल्क जमा केल्याची बँकेच्या पावतीची प्रत (ऑक्टोबर 2018)		
विद्यार्थी कल्याण मंडळ, क्रीडा विभाग, शैक्षणिक प्रवेश विभाग येथे जमा केलेल्या शुल्क/निधीचा प्रॉरेटा पोहोच प्रत (2018)		
जागा मालकी / भाडेकरार संबंधी कागदपत्रे		
Photograph before installation		
अन्डरटेकींग		
AISHE & M.I.S. प्रमाणपत्र		

Checked By _____



SAVITRIBAI PHULE PUNE UNIVERSITY
Ganeshkhurd, Pune-411 007



Challan No. : 18540002464

Name of College and Challan Number:

Jayawant Shikshan Prasarak Mandal Bhivarabai Sawant
Institute of Technology and research
Addr: Survey no 720 Pune Nagar road
Tal: Haweli(excluding Corporation Area) Dist: Pune,
Pincode: 412207 [18540002464]

Total Amount : Rs. 5000.00

Rs.(In words) : Five Thousand rupees only

Applicant Copy
Print Time:21/Aug/2018 13:43:06

Bank Name : BANK OF MAHARASHTRA

Amount (Rs.)

5000.00

Fee Type

Star Visit Charges (111037)

This receipt is valid subject to realization of the payment instrument.



UNDERTAKING OF 5 YEARS CMC

Date: 15/05/2019

To
Bhivarabai Sawant Institute of Technology & Research
Wagholi, Pune-412207.

Subject: - Regarding given undertaking of 5 years CMC to Grid Connected Roof-top System.

Dear Sir,

I the undersigned below M/s.Sunrisers Energy Solutions Pvt. Ltd. is registered as a Channel Partner / Open Category project developers with MEDA. I have installed Grid Connected Roof-top System at given premises. I have given undertaking for 5 years Comprehensive Maintenance Contract (CMC) for this Grid Connected Roof-top System.

- Name of the Beneficiary: - JSPM'S Bhivarabai Sawant Institute of Technology & Research
- Address of the Beneficiary: - JSPM'S Bhivarabai Sawant Institute of Technology & Research
Wagholi, Pune- 412207
- Capacity: -10 KW

For ,
Sunrisers Energy Solutions Pvt. Ltd.



Off: 1212/B2, Seeta Apts, Apte Road, Pune - 411004.
info@sunrisersenergy.com | www.sunrisersenergy.com



Scanned with
CamScanner

Letter of Warranty

Date 20/05/2019

Project: 10 KWp On-Grid Solar Power Plant.

Customer - Bhivarabal Sawant Institute of Technology & Research, Wagholi, 412 207
Address - Bhivarabal Sawant Institute of Technology & Research, Wagholi, 412 207

Dear Sir:

Please accept this letter as a written warranty for the work that we performed & Material Supplied at the above referenced project.

1. Solar Panels- Renesys Solar (325W)
10 Years any Manufacturing defect.& 25 Years Linear Output performance.
2. Inverter- Delta (10KW)
05 Years any manufacturing/performance defect.
3. ACDB/DCDB- 02 Years any manufacturing/performance defect.

Note- Project has been commissioned on 15/05/2019. So warranty period for all above items will be counted from this date only.

For,
Sunrisers Energy Solutions Pvt. Ltd.
1212, B/2, Seeta Appts, Apte Road
Shivajinagar, Pune- 411004.

Email- info@Sunrisersenergy.com
Mob- 7219504046

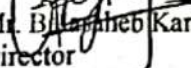
Mr. Bilal Karad.
Director





JAYAWANT SHIKSHAN PRASARAK MANDAL'S

Bhivarabai Sawant Institute of Technology & Research



(Approved by AICTE New Delhi, DTE Mumbai & Affiliated to Savitribai Phule Pune University)

Accredited with B++ Grade by NAAC

Gat No. 719/1 & 2, Wagholi, Pune-Nagar Road, Pune-412207

Ph : 020-067335108, 65217050, 67335100

Telefax : 020-67335100

Website : www.jspm.edu.in / www.bsiotr.org

EN 6311 / CEGP-013100

Prof. Dr. T. J. Sawant
B.E. (Elec.) PGDM, Ph.D
Founder Secretary

Dr. T.K. Nagara
ME. (Civil Engg), Ph.D (Civil Engg)
LMISTE, LMIGS, LMIRC
LMISRMTT, LMIE
Principal

Ref: JSPM/BSIOTR/CSIP/2020-21/14531

Date: 23/12/2020

हमीपत्र

या हमीपत्राद्वारे लिहून देतो / देते की, महाविद्यालयाने परिसंस्थेने सावित्रीबाई फुले पुणे विद्यापीठाव्यतिरिक्त सौर उर्जा उपकरणे बसविण्याकरिता अन्य कोणत्याही शासकीय / निमशासकीय / अशासकीय संस्था / संघटना / वित्तीय संस्था अथवा देणगीदारांकडून आर्थिक सहाय्य / अनुदान घेतलेले नाही, तसेच सादर उपकरणे बसविल्यानंतर कोणत्याही केंद्र / राज्य शासन स्तरावरील अनुदानाकरिता (सबसिडी) प्रस्ताव सादर केलेला नाही . अशाप्रकारे अनुदान / सबसिडी घेतल्यास महाविद्यालय / संस्था संबंधीची माहिती स्वतःहून विद्यापीठाला लेखी स्वरूपात सादर करील .

दिनांक . 23/12/2020



स्वाक्षरी प्राचार्य संचालक

PRINCIPAL

Jayawant Shikshan Prasarak Mandal's
Bhivarabai Sawant Institute of
Technology & Research
Wagholi, Pune-412207



Vision: - "To Satisfy the aspirations of youth force, who want to lead the nation towards prosperity through techno-economic development."
Mission: - "To provide, nurture and maintain an environment of high academic excellence, research and entrepreneurship for all aspiring students, which will prepare them to face global challenges maintaining high ethical and moral standards."



Jayawant Shikshan Prasarak Mandal

(Regd.No: MAH/632/98/ Pune & Trust No. F/14907/98)

PROF. SHIVAJIRAO SAWANT
M.A.D.A.E., D.D.
PRESIDENT

PROF. DR.TANAJI SAWANT
B.E.(Elect.), PGDM, Ph.D
FOUNDER SECRETARY

Regd. Off.: S. No. 80, Pune-Mumbai Bypass Highway, Tathawade, Pune-411033. Phone:(020)22933423,22934084.Fax: (020) 22933424
Corporate Office : "SAWANT CORNER", S.No. 84/2E1/5,3" Floor,Katraj Chowk, New Pune - Mumbai By Pass Highway, Katraj, Pune - 46.
Phone : 020-24317383/84/85. www.jspm.edu.in

जा.क्र. JSPM/BSIT07R/2018-19/8656.

दि.०५.०३.२०१९

हमीपत्र

या हमीपत्राद्वारे लिहून देतो की, भिवराबाई सावंत इंस्टिट्यूट ऑफ टेक्नॉलॉजी अँड रिसर्च, वाघोली, पुणे महाविद्यालयाने गुणवत्ता सुधार योजनेअंतर्गत सौर ऊर्जा उपकरणे वसविण्याकरिता सावित्रीबाई फुले पुणे विद्यापीठाव्यतिरिक्त अन्य कोणत्याही शासकीय/निमशासकीय/अशासकीय संस्था /संघटना,वित्तीय संस्था अथवा देणगीदारांकडून आर्थिक सहाय्य घेतलेले नाही व सौर सौर ऊर्जा उपकरणे वसविण्याकरिता असलेली जागा/इमारत ही संस्थेच्या/महाविद्यालयाच्या मालकीची आहे. तसेच महाविद्यालये/संस्थेने गुणवत्ता सुधार योजनेअंतर्गत आर्थिक वर्ष २०१६-१७ पूर्वी घेतलेल्या उचल रकमेअंतर्गत कोणतेही वांधकाम अपूर्ण नाही.

सचिव किंवा अध्यक्ष
स्वाक्षरी व सील

FOUNDER-SECRETARY
Jayawant Shikshan Prasarak Mandal
Tathawade, Pune - 411 033.



PRINCIPAL
J.S.P.M.'S Bhivarabai Sawant Institute of
Technology & Research
Wagholi, Pune-412207

प्राचार्य/संचालक
स्वाक्षरी व सील
PRINCIPAL

J.S.P.M.'S Bhivarabai Sawant Institute of
Technology & Research
Wagholi, Pune-412207

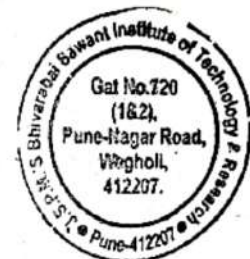

10 Kwp Grid Connected Solar PV Power Plant. Final Comparative Statement.

Sr. No.	Product Description	Qty	GK Energy marketers pvt ltd	Sunrisers Energy Solutions Pvt. Ltd.	Harshal Enterprises
1	10 Kwp Grid Connected Solar PV Power Plant. Design , Supply , Erection and Commissioning Of A Roof Top Grid Tie Solar PV Power Generations Plant With Standard Length Of Wires. The Solar Power Will Consists Of Required No. Of SPV Panels, inverter and with all the electrical items suitable to designed installed capacity	1	680000	615500	640000
TOTAL			680000	615500	640000
5% GST On Material			23800	28900	32000
18%GST On Installation & Labour Work			36720	5600	
Grand Total			740520	650000	672000
Other Terms & Condition					
Delivery & Installation	includes in total cost				
Warranty	Solar PV Modules 10 yrs PV Inverter 5 years				
Operation & Maintenance	2 years free maintenance after 2 years AMC will be signed.				
Services	yearly 3 times visit for flushing all & emergency call should be attend				
Payment Terms	70% adv with PO 30% immediately after completion of work.	50% adv with PO 50% after completion & satisfaction report of the work.	50% adv with PO 50% against perform invoice .		



01/5/20
 Founder Secretary JSPM

PRINCIPAL
S.P.M.'S Dikravarabai Sawant Institute of Technology & Research
Waghodi, Pune- 412207

BSIOTR 2019-20
GUT NO.720, PUNE-NAGR ROAD, WAGHOLI, PUNE-

Sunrisers Energy Solutions Pvt.Ltd.
Ledger Account

1-Apr-2019 to 31-Mar-2020

Date	Particulars	Vch Type	Vch No.	Debit	Page 1 Credit
1-4-2019	Cr Opening Balance			3,25,000.00	
14-6-2019	Dr Roof Top Solar System Being purchase of 10kwp on Grid Rooftop solar system (E & TC Yogesh Angal)	Journal	Bill No-SES/GT/319		6,50,000.00
2-12-2019	Cr PNB-0386002111027614 Being payment for PO 1316 dt.08.02.2019 Purchase of On Grid Roof Top Solar PV System Bill No-SES/GT/319 dt.14.06.2019 Against Corporate Office Through Payment	Payment	Che No-493676	3,25,000.00	
				6,50,000.00	6,50,000.00

Installed on 0-1 buildings

Work Completion Report

Site: - JSPM's BSIOTR

Date: - 03/04/2019

Customer Name: - JSPM Group of Institutes
Mr. Anil Bhosale.

This is to certify that **10 KW** Grid Connected Solar power plant , as per the MNRE Standards has been installed, commissioned and tested successfully by **Sunrisers Energy Solution Pvt. Ltd.** On 01/04/2019 at "JSPM's Bhivarabai Sawant Institute Of Technology & Research", Wagholi, Pune.

System Details-

01	Size	10 KW
02	Capacity of Inverter	10 KW (DELTA)
03	Solar Modules	31 Modules of 325Wp (Renewsys)
04	Structure	Hot-dip Galvanized with 86 microns

Note:-

For,
Sunrisers Energy Solution Pvt.Ltd.
Name & Signature of Site Engineer
Ashok. Gaikwad



Name & Signature of Principal/Director
[Signature]
JSPM's Bhivarabai Sawant Institute of Technology & Research
Wagholi, Pune - 412207



Off: 1212/B2, Seeta Apts, Apte Road, Pune - 411004.
info@sunrisersenergy.com | www.sunrisersenergy.com

Date: 28/11/19

RECEIPT

This is to acknowledge the receipt of full / advance Payment from BSJOTR
_____ against PO Number 3016 Dated 08/02/19 Received by Cheque/
Cash amount of Rs. 325000 (In words Three Lacs twenty five thousand)
Bank Name PNB Branch Ch.No. 493676 Date 28/11/2019

(Signature)

Thanking You.

Authorised Signatory.



Date:- 09/02/2019

Receipt

This is to acknowledge the receipt of full/Advance Payment from
..... BSIOTR against
PO Number 3016 dated 08/2/19 received by Cheque / Cash amount of Rs.
325000 (words Three Lakh twenty five thousand only) Bank Name
P.N.B. Branch. Ch. No. 493662 Date 09/02/19

Thanking you.

Authorised Signatory.



Signature

Work Completion Report

Site: - JSPM's BSIOTR

Date: - 03/04/2019

Customer Name: - JSPM Group of Institutes
Mr. Anil Bhosale.

This is to certify that **10 KW** Grid Connected Solar power plant , as per the MNRE Standards has been installed, commissioned and tested successfully by **Sunrisers Energy Solution Pvt. Ltd.** On 01/04/2019 at "JSPM's Bhivarabai Sawant Institute Of Technology & Research", Wagholi, Pune.

System Details-

01	Size	10 KW
02	Capacity of Inverter	10 KW (DELTA)
03	Solar Modules	31 Modules of 325Wp (Renewsys)
04	Structure	Hot-dip Galvanized with 86 microns

Note:-

For,
Sunrisers Energy Solution Pvt.Ltd.
Name & Signature of Site Engineer
Ashok. Gaikwad



Name & Signature of Principal/Director
[Signature]
Principal
JSPM's Bhivarabai Sawant Institute of Technology & Research
Wagholi, Pune-412207

Off: 1212/B2, Seeta Apts, Apte Road, Pune - 411004.
info@sunrisersenergy.com | www.sunrisersenergy.com

Utilization Certificate

Certified that the grant of Rs.800,000 (Rupees Eight Lakh Only) has been sanctioned to Jayawant Shikshan Prasarak Mandal Bhivarabai Sawant Institute of Technology and research Addr: Survey no 720 Pune Nagar road Ta; Haveli(excluding Corporation Area) Dist: Pune by the Savitribai Phule Pune University towards following proposals An expenditure of Rs.963,378 (Rupees Nine Lakh Sixty Three Thousand Three Hundred Seventy Eight And Forty Paise Only) has been incurred for the purpose for which it was sanctioned and in accordance with the terms and conditions as laid down by the University. If as a result of check or audit objection, some irregularity is noticed at a later stage, action will be taken to refund, adjust or regularize the objected amount.

S. No.	Application ID	Proposal Name	Sanction Amount	Total Expenditure
1	CRS181310001	Purchase of Rooftop Solar System	500,000	650,000
2	EQP191310001	Purchase of Lab and Educational Equipments	100,000	138,060
3	PSE191310002	Purchase of Sports Equipment	100,000	134,512
4	SCW191310003	Organizing Seminar/Conference/Workshop (State)	100,000	40,806
Total			800,000	963,378

 Name, Signature & Seal of
PRINCIPAL
 Principal / Director
 Jayawant Shikshan Prasarak Mandal's
 Bhivarabai Sawant Institute of
 Technology & Research
 Wagholi, Pune-412207
 Date :-
 Place :-

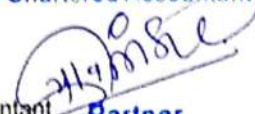

For P. C. PATIL & ASSOCIATES
Chartered Accountants

 Chartered Accountant
 Sign, Seal & Regn. No.
Partner
CA YUVRAJ BHANDARE
M. No. 130266
 UDIN :- 20130266 AAAAMQ 7095



Savitribai Phule Pune University
School of Energy Studies
Final Inspection Report of Solar PV system installed under QIP of SPPU

1.	Name of the College	:	JSPM's Bhivarabai Sawant Institute of Technology & Reseach
2.	Name of the Principal / Director and contact details	:	Director- Dr. T. K. Nagraj Contact- 9922914761
3.	University's Sanction details (Enclose copy)	:	Attached
4.	Prefeasibility Report details (Enclose copy)	:	Attached
5.	Commissioning Date	:	15 June 2019
6.	Type of the System (Off-grid/hybrid/gid-tie)	:	Grid-Tie
7.	Whether net metering availed	:	NA
8.	Capacity (in KWp)	:	10 KW
9.	Total Sanction load of the college (in KW)	:	380 kW
10.	Details of Remote monitoring System: Web address, user id and password	:	Web-http://www.injectsolar.com/live/index.html USER NAME: JSPM_BSIOTR PASSWORD: JSPM_BSIOTR
11.	Details of the vendor (Address, email & contact no.)	:	Sunrisers Energy Solutions Pvt. Ltd. Add- 1212,B/2, Seeta Appts, Apte Road, Shivajinagar, Pune-411004 Mr. Balasaheb Karad Mob-7219504046 Email- info@sunrisersenergy.com
12.	Photographs of the system (Attach photographs)	:	Attached
13.	First installment release status	:	Received/ Not received Amount Received: 2,50,000/- Date of receipt: 8/3/2019

उर्जा अभ्यास प्रणाली
 सावित्रीबाई फुले पुणे विद्यापीठ
 आरक क्रमांक:.....

Recd by
 J. K. Kulkarni
 20/7/2019

Sr. No.	Components	Standard Specification as per Work Order	Observation/ Remarks
1	Solar PV modules	The Modules shall contain (Solar PV) Crystalline Silicon Solar Cell Modules and they must be IEC 61215 / IS 14286 standard.	Ok
		No. of Module (in Nos.)	31
		SPV Module Capacity (in Wp)	325
		Project Capacity (in KW)	10 KW
		RFID Tag	
		Purchase Order of SPV modules (checking indigenous SPV modules).	
	Module Mounting structure	Hot dip galvanized MS mounting structures may be used for mounting the modules / panels / arrays. Minimum thickness of galvanization should be at least 80 microns.	Provided
		It shall withstand the wind speed of respective wind zone (wind speed of 150 km/ hour). Mounting structure steel shall be as per latest IS 2062: 1992 and galvanization of the mounting structure shall be in compliance of latest IS 4759. (as per EoI specifications)	Provided
	Junction Boxes	• The junction boxes shall be made of GRP / FRP / Powder Coated Aluminum /cast aluminum alloy with full dust, water and vermin proof.	Provided
		• The JBs shall be such that input & output termination can be made through suitable cable glands. All wires / cables must be terminated through cable lugs.	Provided
		• Copper bus bars / terminal blocks housed in the junction box with suitable termination threads Conforming to IP65 standard and IEC 62208 Hinged door with EPDM rubber gasket to prevent water entry. Provision of earthings • Each Junction Box shall have High quality Suitable capacity Metal Oxide Varistors (MOVs) / SPDs, suitable Reverse Blocking Diodes.	Provided
		• Make of JB:	Energica/ABB

DC DISTRIBUTION BOARD	<ul style="list-style-type: none"> It shall have sheet from enclosure of dust & vermin proof conform to IP 65 protection 	Provided
Battery Bank (If Any).	<ul style="list-style-type: none"> The cells must be as per IEC Standard & MNRE approved. • Make: 	Capacity: Voltage-V Amp-Ah No. of Batteries:
MNRE approved Charge Controller unit (If Any)	<ul style="list-style-type: none"> Capacity: Voltage.....V AmpAh 	NA
MNRE approved Grid Tie Inverter Make: Delta Model: RPI M10A Sr. No: 01M19403 73Wj	<ul style="list-style-type: none"> Nominal Capacity: ...10 KW... Input Voltage¹⁰⁰⁰.....V DC Nominal, The voltage variation shall be as per change in array output, Output Voltage 440 V, 50 Hz, 1φ, Regulation: From minimum to maximum voltage 1%, Output Frequency: 50 Hz, + 0.5 Hz, 200% for 30 Second, Efficiency: 80% at 50% of load and More than 90% at full load 0.8 PF. Protection against Islanding of grid as per IEEE 1547/UL 1741/ IEC 62116 or equivalent BIS standard. 	Capacity 10 KW Make- Delta.
AC Distribution Panel Board	<ul style="list-style-type: none"> All switches and the circuit breakers, connectors should conform to IEC 60947, part I, II and III/ IS 60947 part I, II and III. AC Distribution Panel Board should have necessary surge arrestors. 	Provided
	<ul style="list-style-type: none"> Cables must properly align and insulated. 	Provided
Danger Notice Plates for system having capacity 10KW or above.	<ul style="list-style-type: none"> Danger boards should be provided as and where necessary as per IE Act. /IE rules as amended up to date. The inscriptions shall be in local language, Hindi and English. 	Provided
Earthing Systems.	<ul style="list-style-type: none"> The Earthing system for array and distribution system & SPV Power Plant Each array structure of the PV yard should be grounded/ earthed properly as per IS:30431987 	Provided
Tools kit (for system having capacity 10KW or above)	<ul style="list-style-type: none"> Necessary tools kit is to be provided along with the each Power Plant for any routine maintenance or immediate repair 	Provided

Training, Operation Manual & Display Board	• Training to the user for operation and maintenance of the system.	Provided
	• Supply of manual for Operation and Maintenance in two languages i.e. in English and in Marathi to Beneficiary.	Provided
	• Display Board of size 3 ft x 3 ft which gives detailed circuit diagram of the system with its description.	Provided
Net Meter	• Details of net meter and Date of commissioning. (Get the details of release order from utility with details of meter.)	NA
Lightening arresster	Lightning protection should be provided as per IEC 62305 standards.	Provided
Comprehensive Maintenance Contract (CMC)	Yes	Provided for 5 Years
Exact Geographic coordinates of the site.	Longitude: Latitude: Latitude N 18° 35' 18.52872'' Longitude E 74° 0' 10.872''	

The above system is installed, commissioned and found working satisfactory during the inspection and it is handed over to the beneficiary/user agency.

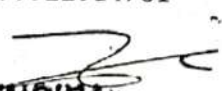
Signature of the Principal/Director	Signature of the Vendor/Supplier
Name: Dr. T. K. Nagraj	Name: Sunrisers Energy Solutions Pvt Ltd
Contact number: 9922914761	Mr. Balasaheb Karad
Date:	Contact number: 7219504046
	Date:
PRINCIPAL	
J.S.P.M.'S Bhivarabai Sawant Institute of Technology & Research Wadi, Pune- 412207	SUNRISERS ENERGY SOLUTIONS PVT. LTD.

Remark: Recommended for release **second installation**





Signature of Authority
School of Energy Studies, SPPU

**JSPM's
Bhivarabai Sawant Institute of Technology and Research,
Wagholi, Pune**

Sr. No	Particulars of Equipment	Name of The Supplier	Bill No.& Date	Amt in Rs.
1.	Supply of 10kWp On –Grid Rooftop Solar System	Sunrisers Energy Solutions Pvt.Ltd. Add-1212,B/2,Seeta Appts,Apte Roa,Shivajinagar,Pune-411004 Mr.Balasaheb Karad Mob-7219504046 Email-info@sunrisersenergy.com	Bill No. SES/GT/319. Date: 14/06/2019 PO No. JSPM/BSIOTR/PO/13016/2019	6,50,000.00/-



Dr. YOGESH S.ANGAL
Name & Signature of Co-Ordinator



Dr.T.K.NAGARAJ
Name, Signature & Seal of
Principal/ Director
PRINCIPAL

J.S.P.M.'S Bhivarabai Sawant Institute of
Technology & Research
Wagholi, Pune- 412207



Chartered Accountant
Sign.,Seal & Regn.No.

For P. C. PATIL & ASSOCIATES
Chartered Accountants

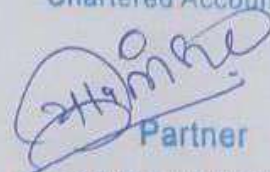

Partner

CA YUVRAJ BHANDARE
M. No. 130266



Work Completion Report

Site: - JSPM's BSIOTR

Date: - 03/04/2019

Customer Name: - JSPM Group of Institutes
Mr. Anil Bhosale.

This is to certify that **10 KW** Grid Connected Solar power plant, as per the MNRE Standards has been installed, commissioned and tested successfully by **Sunrisers Energy Solution Pvt. Ltd.** On 01/04/2019 at "JSPM's Bhivarabai Sawant Institute Of Technology & Research", Wagholi, Pune.

System Details-

01	Size	10 KW
02	Capacity of Inverter	10 KW (DELTA)
03	Solar Modules	31 Modules of 325Wp (Renewsys)
04	Structure	Hot-dip Galvanized with 86 microns

Note:-

For,
Sunrisers Energy Solution Pvt.Ltd.
Name & Signature of Site Engineer

Ashok Gaikwad



Name & Signature of Principal/Director

[Signature]
Principal
JSPM's BSIOTR
Technology & Research
Wagholi, Pune-412207



Off: 1212/B2, Seeta Apts, Apte Road, Pune - 411004.
info@sunrisersenergy.com | www.sunrisersenergy.com

**JSPM'S BHIVARABAI SAWANT INSTITUTE OF TECHNOLOGY
AND RESEARCH, WAGHOLI, PUNE -412207**

Photographs of Construction and Installation of Rooftop Solar Systems



Photo 1: Solar Panel Installed



Photo 2: Solar Panel Installed with Project Coordinator-Dr.Yogesh S. Angal(HOD(E&TC))

**JSPM'S BHIVARABAI SAWANT INSTITUTE OF TECHNOLOGY
AND RESEARCH, WAGHOLI, PUNE -412207**

Photographs of Construction and Installation of Rooftop Solar Systems



Photo 3- Solar Panel Details Installed

**JSPM'S BHIVARABAI SAWANT INSTITUTE OF TECHNOLOGY
AND RESEARCH, WAGHOLI, PUNE -412207**

Photographs of Construction and Installation of Rooftop Solar Systems



Photo 3- Solar Panel Details Installed with Project Coordinator Dr.Y. S. Angal (HOD (E&TC))

Solar Panel Control and Monitoring Panel

Title of the Project	RoofTop Solar System
Cost of Project	Rs.6,50,000/-
Sanctioned Amount	Rs.5,00,000/-
Funding Agency	QIP, Planning and Development Savitribai Phule Pune University
Sanction Details	Letter No. SPPU/NVV/63 dated 30/01/2019
Specifications	
Type of System	Grid-Tie
Capacity(in KWP)	10KW
MNRE approved Grid Tie Inverter	Make: Delta
Solar PV Module	31 Qty
Structure	Ms Hot Dip Galvanized
Remote Monitoring System	Included
Inverter	Delta
Details of Vendor	
Sunrises Energy Solutions Pvt Ltd, Pune	
Principal Investigator	Dr.Yogesh S. Angal HOD(E&TC)

**JSPM'S BHIVARABAI SAWANT INSTITUTE OF TECHNOLOGY
AND RESEARCH, WAGHOLI, PUNE -412207**

Photographs of Construction and Installation of Rooftop Solar Systems

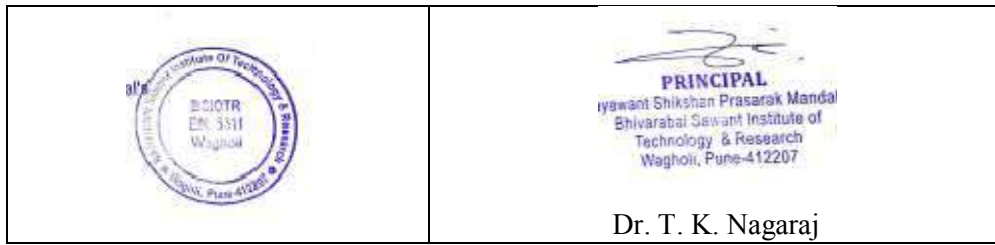

PN-28

P3/2018-19

ANNEXURE 3



Savitribai Phule Pune University
School of Energy Studies
Final Inspection Report of Solar PV system installed under QIP of SPPU



1.	Name of the College	:	JSPM's Bhivarabai Sawant Institute of Technology & Reseach
2.	Name of the Principal / Director and contact details	:	Director- Dr. T. K. Nagraj Contact- 9922914761
3.	University's Sanction details (Enclose copy)	:	Attached
4.	Prefeasibility Report details (Enclose copy)	:	Attached
5.	Commissioning Date	:	15 June 2019
6.	Type of the System (Off-grid/hybrid/gid-tie)	:	Grid-Tie
7.	Whether net metering availed	:	NA
8.	Capacity (in KWp)	:	10 KW
9.	Total Sanction load of the college (in KW)	:	380 KW
10.	Details of Remote monitoring System: Web address, user id and password	:	Web-http://www.injectsolar.com/live/index.html USER NAME: JSPM_BSIOTR PASSWORD: JSPM_BSIOTR
11.	Details of the vendor (Address, email & contact no.)	:	Sunrisers Energy Solutions Pvt. Ltd. Add- 1212,B/2, Seeta Appts, Apte Road, Shivajinagar, Pune-411004 Mr. Balasaheb Karad Mob-7219504046 Email- info@sunrisersenergy.com
12.	Photographs of the system (Attach photographs)	:	Attached
13.	First installment release status	:	Received/ Not received Amount Received: 250,000 ₹ Date of receipt: 8/3/2019

Sr. No.	Components	Standard Specification as per Work Order	Observation/ Remarks
1	Solar PV modules	The Modules shall contain (Solar PV) Crystalline Silicon Solar Cell Modules and they must be IEC 61215 / IS 14286 standard.	Ok
		No. of Module (in Nos.)	31
		SPV Module Capacity (in Wp)	325
		Project Capacity (in KW)	10 KW
		RFID Tag	
		Purchase Order of SPV modules (checking indigenous SPV modules).	
Module Mounting structure	Hot dip galvanized MS mounting structures may be used for mounting the modules / panels / arrays. Minimum thickness of galvanization should be at least 80 microns.	Provided	
	It shall withstand the wind speed of respective wind zone (wind speed of 150 km/ hour). Mounting structure steel shall be as per latest IS 2062: 1992 and galvanization of the mounting structure shall be in compliance of latest IS 4759. (as per EoI specifications)	Provided	
Junction Boxes	• The junction boxes shall be made of GRP / FRP / Powder Coated Aluminum /cast aluminum alloy with full dust, water and vermin proof.	Provided	
	• The JB's shall be such that input & output termination can be made through suitable cable glands. All wires / cables must be terminated through cable lugs.	Provided	
	• Copper bus bars / terminal blocks housed in the junction box with suitable termination threads Conforming to IP65 standard and IEC 62208 Hinged door with EPDM rubber gasket to prevent water entry. Provision of earthings • Each Junction Box shall have High quality Suitable capacity Metal Oxide Varistors (MOVs) / SPDs, suitable Reverse Blocking Diodes.	Provided	
	• Make of JB:	Energica/ABB	

DC DISTRIBUTION BOARD	<ul style="list-style-type: none"> It shall have sheet from enclosure of dust & vermin proof conform to IP 65 protection 	Provided
Battery Bank (If Any).	<ul style="list-style-type: none"> The cells must be as per IEC Standard & MNRE approved. • Make: 	Capacity: Voltage-V Amp-Ah No. of Batteries:
MNRE approved Charge Controller unit (If Any)	<ul style="list-style-type: none"> Capacity: Voltage.....V AmpAh 	NA
<p>MNRE approved Grid Tie Inverter</p> <p>Make: Delta</p> <p>Model: RPI M10A</p> <p>Sr. No: 01M19403 73WJ</p>	<ul style="list-style-type: none"> Nominal Capacity: ...10 KW... Input Voltage: 1000 V DC Nominal, The voltage variation shall be as per change in array output, Output Voltage: 440 V, 50 Hz, 1φ, Regulation: From minimum to maximum voltage 1%, Output Frequency: 50 Hz, + 0.5 Hz, 200% for 30 Second, Efficiency: 80% at 50% of load and More than 90% at full load 0.8 PF. Protection against Islanding of grid as per IEEE 1547/UL 1741/ IEC 62116 or equivalent BIS standard. 	Capacity 10 KW Make- Delta.
AC Distribution Panel Board	<ul style="list-style-type: none"> All switches and the circuit breakers, connectors should conform to IEC 60947, part I, II and III/ IS 60947 part I, II and III. AC Distribution Panel Board should have necessary surge arrestors. 	Provided
	<ul style="list-style-type: none"> Cables must properly align and insulated. 	Provided
Danger Notice Plates for system having capacity 10KW or above.	<ul style="list-style-type: none"> Danger boards should be provided as and where necessary as per IE Act. /IE rules as amended up to date. The inscriptions shall be in local language, Hindi and English. 	Provided
Earthing Systems.	<ul style="list-style-type: none"> The Earthing system for array and distribution system & SPV Power Plant Each array structure of the PV yard should be grounded/ earthed properly as per IS:30431987 	Provided
Tools kit (for system having capacity 10KW or above)	<ul style="list-style-type: none"> Necessary tools kit is to be provided along with the each Power Plant for any routine maintenance or immediate repair 	Provided

Training, Operation Manual & Display Board	• Training to the user for operation and maintenance of the system.	Provided
	• Supply of manual for Operation and Maintenance in two languages i.e. in English and in Marathi to Beneficiary.	Provided
	• Display Board of size 3 ft x 3 ft which gives detailed circuit diagram of the system with its description.	Provided
Net Meter	• Details of net meter and Date of commissioning. (Get the details of release order from utility with details of meter.)	NA
Lightening arrester	Lightning protection should be provided as per IEC 62305 standards.	Provided
Comprehensive Maintenance Contract (CMC)	Yes	Provided for 5 Years
Exact Geographic coordinates of the site.	Longitude: Latitude: Latitude N 18° 35' 18.52872'' Longitude E 74° 0' 10.872''	

The above system is installed, commissioned and found working satisfactory during the inspection and it is handed over to the beneficiary/user agency.

Signature of the Principal/Director	Signature of the Vendor/ Supplier
Name: Dr. T. K. Nagraj	Name: Sunrisers Energy Solutions Pvt Ltd
Contact number: 9922914761	Mr. Balasaheb Karad
Date: 	Contact number: 7219504046
	Date: 

Remark: Recommended for release of second installment

Recommended for handover of payment.

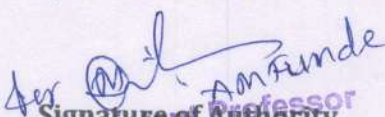
 Signature of Authority
 School of Energy Studies
 Savitribai Phule Pune University
 Pune - 411 007



SUNRISERS ENERGY SOLUTIONS PVT. LTD.



SAVITRIBAI PHULE PUNE UNIVERSITY
Ganeshkhurd, Pune-411 007



Challan No. : 18540002464

Name of College and Challan Number:

Jayawant Shikshan Prasarak Mandal Bhivarabai Sawant
Institute of Technology and research
Addr: Survey no 720 Pune Nagar road
Tal: Haweli(excluding Corporation Area) Dist: Pune,
Pincode: 412207 [18540002464]

Total Amount : Rs. 5000.00

Rs.(In words) : Five Thousand rupees only

Applicant Copy
Print Time:21/Aug/2018 13:43:06

Bank Name : BANK OF MAHARASHTRA

Amount (Rs.)

5000.00

Fee Type

Star Visit Charges (111037)

This receipt is valid subject to realization of the payment instrument.



DEPARTMENT OF ELECTRONICS AND TELECOMMUNICATION ENGINEERING

7.1.2 Energy conservation initiative 2022-23

Students of Second Year of Electronics and Telecommunication Engineering has implemented a room automation project in the view of conserving energy.

The project titled “**IoT Based Automatic room control using Arduino**” has been completed and successfully installed in Software and Research Lab.

Objective of project:

To control the connected electrical appliances remotely to reduce energy wastage.

Introduction:

With the use of mobile phone, automatic room control system is used to control electrical appliances remotely (from any part of the world). Consequently, greater amount of energy will be saved and hence the natural resources. This system is designed using Relays, Arduino and GSM module. The electrical appliances are controlled by sending a text message from any mobile located in any part provided it has a GSM connectivity.

Working:

A message is sent from user's mobile phone to the GSM module enable with sim, the message is the communicated with arduino. The controller i.e. arduino compares the message received from GSM module with the stored messages in arduino memory. If the message is valid microcontroller takes action accordingly. According to the message received function programed i.e. ON or OFF of the relay that are connected to arduino is executed. Thus the load i.e. light, fans etc. connected to the relay are turned ON or OFF remotely and thus save energy if appliances are not needed.

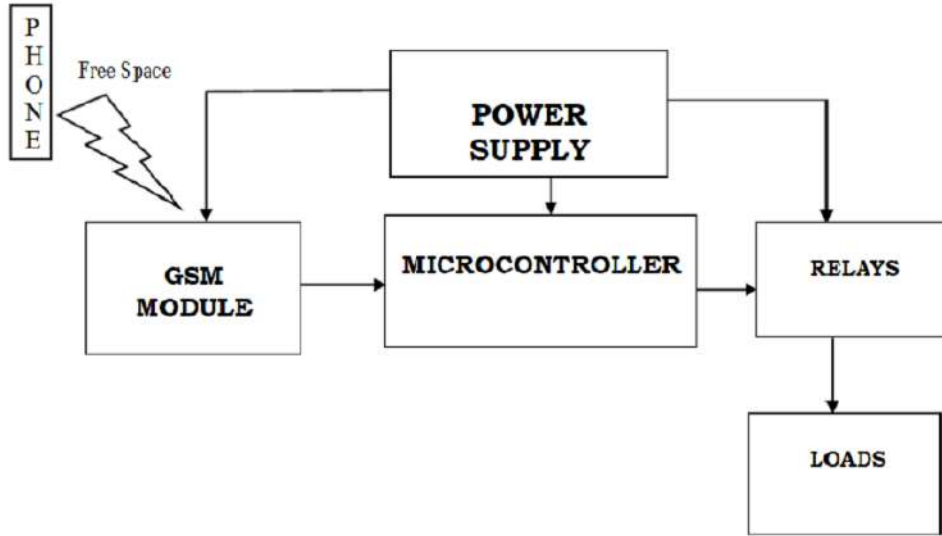

System Block Diagram

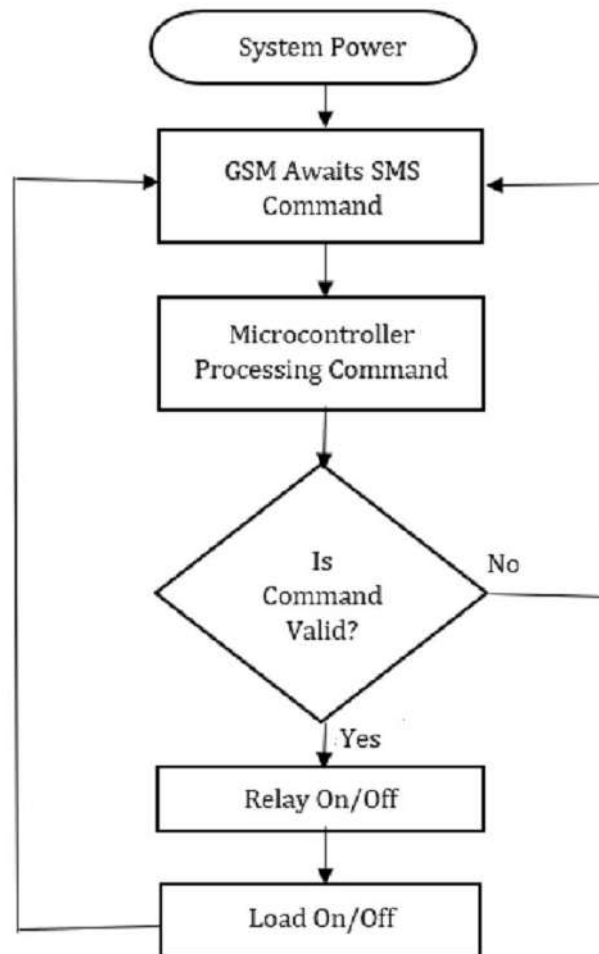

Flow of the project



Vision: "To Satisfy the aspirations of youth force, who want to lead the nation towards prosperity through techno-economic development"

Mission: "To provide, nurture and maintain an environment of high academic excellence, research and entrepreneurship For all aspiring Students, which will prepare them to face global challenges maintaining high ethical and moral Standards"





Implementation of the project



GPS Map
Camera Lite

Wagholi, JSPMS BHIVARABAI SAWANT INSTITUTE, Wagholi,
Maharashtra 412207, India

Latitude
18.5859962°

Longitude
74.0037396°

Local 11:15:30 AM
GMT 05:45:30 AM

Altitude 599 meters
Friday, 02.06.2023

Software Lab



Vision: "To Satisfy the aspirations of youth force, who want to lead the nation towards prosperity through techno-economic development"

Mission: "To provide, nurture and maintain an environment of high academic excellence, research and entrepreneurship For all aspiring Students, which will prepare them to face global challenges maintaining high ethical and moral Standards"





Installed project in Software and Research Lab

Project prepared by:

1. Abhishekh Adhav (SE, E&TC)
2. Parjanya Kulkarni (SE, E&TC)

[Handwritten Signature]
H. O. D.

Electronics & Telecommunication Dep.
Bhivarabai Sawant Institute of
Technology & Research
Wagholi, Pune- 412 207



Vision: "To Satisfy the aspirations of youth force, who want to lead the nation towards prosperity through techno-economic development"

Mission: "To provide, nurture and maintain an environment of high academic excellence, research and entrepreneurship For all aspiring Students, which will prepare them to face global challenges maintaining high ethical and moral Standards"





JAYAWANT SHIKSHAN PRASARAK MANDAL's Bhivarabai Sawant Institute of Technology & Research

(Approved by AICTE New Delhi, DTE Mumbai & Affiliated to Savitribai Phule Pune University)

Accredited with B++ Grade by NAAC

Gat No. 719/1 & 2, Wagholi, Pune-Nagar Road, Pune-412207

Ph : 020-067335108, 65217050, 67335100

Telefax : 020-67335100

Website : www.jspm.edu.in / www.bsiotr.org

[EN 6311] / [CEGP-013100]



Prof. Dr. T. J. Sawant
B.E. (Elec.) PGDM, Ph.D
Founder Secretary

Dr. T.K. Nagaraj
ME. (Civil Engg), Ph.D (Civil Engg)
LMISTE, LMIGS, LMIRC
LMISRMTT, LMIE
Principal



Library & Reading Hall



VC Room

Central Computer Lab



JAYAWANT SHIKSHAN PRASARAK MANDAL's Bhivarabai Sawant Institute of Technology & Research

(Approved by AICTE New Delhi, DTE Mumbai & Affiliated to Savitribai Phule Pune University)

Accredited with B++ Grade by NAAC

Gat No. 719/1 & 2, Wagholi, Pune-Nagar Road, Pune-412207

Ph : 020-067335108, 65217050, 67335100

Telefax : 020-67335100

Website : www.jspm.edu.in / www.bsior.org

[EN 6311] / [CEGP-013100]



Prof. Dr. T. J. Sawant
B.E. (Elec.) PGDM, Ph.D
Founder Secretary

Dr. T.K. Nagaraj
ME. (Civil Engg), Ph.D (Civil Engg)
LMISTE, LMIGS, LMIRC
LMISRMTT, LMIE
Principal



Football Ground



Cricket Ground



Basketball Ground



Volleyball Ground



JAYAWANT SHIKSHAN PRASARAK MANDAL's Bhivarabai Sawant Institute of Technology & Research

(Approved by AICTE New Delhi, DTE Mumbai & Affiliated to Savitribai Phule Pune University)

Accredited with B++ Grade by NAAC

Gat No. 719/1 & 2, Wagholi, Pune-Nagar Road, Pune-412207

Ph : 020-067335108, 65217050, 67335100

Telefax : 020-67335100

Website : www.jspm.edu.in / www.bsiotr.org

[EN 6311] / [CEGP-013100]



Prof. Dr. T. J. Sawant
B.E. (Elec.) PGDM, Ph.D
Founder Secretary

Dr. T.K. Nagaraj
ME. (Civil Engg), Ph.D (Civil Engg)
LMISTE, LMIGS, LMIRC
LMISRMTT, LMIE
Principal

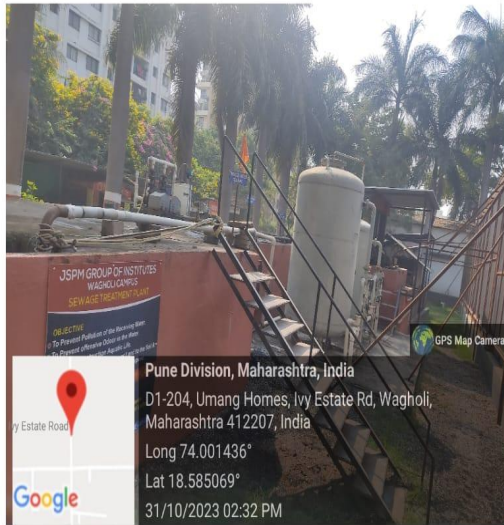

Sewage Treatment Plant



Water Treatment Plant

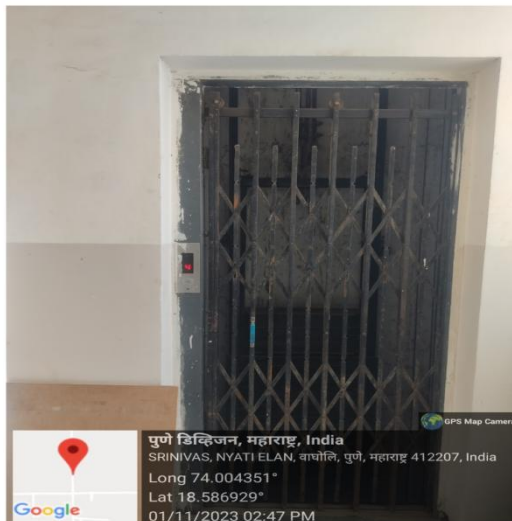

Lift



Ramp



JAYAWANT SHIKSHAN PRASARAK MANDAL's
Bhivarabai Sawant Institute of Technology & Research

(Approved by AICTE New Delhi, DTE Mumbai & Affiliated to Savitribai Phule Pune University)

Accredited with B++ Grade by NAAC

Gat No. 719/1 & 2, Wagholi, Pune-Nagar Road, Pune-412207

Ph : 020-067335108, 65217050, 67335100

Telefax : 020-67335100

Website : www.jspm.edu.in / www.bsiotr.org

EN 6311 / CEGP-013100



Prof. Dr. T. J. Sawant
B.E. (Elec.) PGDM, Ph.D
Founder Secretary

Dr. T.K. Nagaraj
ME. (Civil Engg), Ph.D (Civil Engg)
LMISTE, LMIGS, LMIRC
LMISRMTT, LMIE
Principal

*****Programs Accredited by National Board of Accreditation (NBA), New Delhi *****

*** Electrical Engineering * Electronics and Telecommunication Engineering. * Information Technology**

Date: 01/01/2019

ENVIRONMENT AND ENERGY USAGE POLICY

JSPM's Bhivarabai Sawant Institute of Technology and Research, Pune is one of the Premier Institutions in providing quality education for engineering students and it aims to produce professionals of technically competent and socially responsible. The institute has formulated the policy on environmental and energy usage to affirm the Institution's commitment to environmental and energy issues and to solve those issues through continuous improvement in environment-related activities. The policy aims to ensure environmental and energy compliance by adhering the sound environment and energy policies in the academic and administration departments of the institution.

The institute understands that ecological sustainability is the key component of social responsibility and therefore strives to conserve the environment by adhering eco-friendly approach. This includes conserving raw materials, energy, water and waste management.

The environment and energy policy connects all the sectors of the institution and it applies to all its stakeholders and the various activities carried out by the institution. It will help us to improve efficiency and environmental awareness in our everyday activities, thus helping us to realize our responsibilities and commitment to the conservation of natural resources and to limit their usage.

The policy is to conserve the natural environment, provide sustainable solutions and control energy consumption in order

- To create awareness among students about conserving natural resources and the development of a sustainable environment for national prosperity.
- To adopt an ethical and environment-friendly approach in all the activities of the institution to conserve the natural environment.
- To evolve futuristic technologies and develop engineering solutions that help us to sustain the environment and energy in an optimum way.
- To build a society that has an attitude of conservation and harmony with nature.

POLICY DOCUMENT ON ENVIRONMENT AND ENERGY USAGE

Extension and Outreach Activities under NSS and Departmental students associations sensitize the students towards environment sustainability through activities like cleanliness drives, tree plantations, speeches on environment and sustainability etc. Few audit courses are also offered to students which address the issues related to Environment and Energy usage and alternate sources of energy. Department of IT, Electrical and Electronics and Telecommunication Engineering have implemented student projects on renewable energy sources and energy conservation initiatives using latest technology in the departments.

On the campus in which the institute is located Sewage Treatment Plant is available which treats wastewater from various establishments on the campus. This treated water is used for gardening purposes to keep the campus green and clean. This helps in the conservation of clean water.

The campus is lush green with various types of plants and trees which produce lots of organic waste which is used after composting.

Solar energy systems are installed on rooftops which save a certain amount of energy. LED tubes/bulbs are used to conserve energy. Boards are displayed in classrooms and laboratories to switch off the lights, fans etc when not in use.

The policy document of the institute is aimed

- To assess our energy usage and measure its impact on the environment.
- To reduce local air pollution emissions using environment-friendly vehicles, including bicycles, public transportation and use of pedestrian-friendly roads.
- To maximize the natural ventilation for maximum conservation of energy.
- To install photovoltaic solar panels for the generation of alternate energy. To install LED bulbs in the complete campus to save energy.
- To develop a systematic waste management mechanism. To maintain the rainwater harvesting unit.
- To undertake a tree plantation drive.
- To use technological advancement to improve our energy consumption.
- To educate our faculty members and students on environmental knowledge and skills to improve our environmental performance.
- To provide information and training opportunities on energy-saving measures.
- To offer opportunities for faculty members and students to engage in initiatives that contribute to environmental protection.
- To train our faculty members and students and make them 'Go Green Specialists' and partners to plant trees each year.
- To take up environment, energy and green audit every year.
- To review the activities related to measures and initiatives taken for environment sustainability and energy usage.



Principal

PRINCIPAL

Bhivarabai Sawant Institute Of Technology & Research
Wagholi, Pune- 412207.

Client Name	J.S.P.M
Site Name & Address	Wagholi
Type of Plant	CLARIFFIR/PSF/ACF/SOFT/RO/DM/MB/ETP/STP
Type of Service	Supply/Erection/Commissioning/After Sales-Service/ After Warrantee/Old Plant/Service for others plant
Capacity or other details of plant. (i.e Dia/Hos/Piping/Valves/Pumps/Etc.)	S.T.P 500m ³ /day
Concern Person & designation	Mr. Rasendra midgete
Contact No. of Concern Person & Site	mob - 7387415830
Complaints or Observation in Plant/Systems (If require attach supplement)	S.T.P Aceto Not working, Air Blower is sum
Work Carried out or Action taken by Service engineer (If require attach supplement)	1) Filter feed Pump float switch change & Air Blower no-1 & 2 service
Material / Spares delivered (Pls attach acknowledge copy of Delivery Challan or description of goods)	Yes / No. float switch 01 & Diesel oil etc
Require material / spares or Service next time. (If yes then mention description of Goods & type of service)	Yes / No. float switch 01 for Raw water pump
Plant within Warrantee ?	Yes / No (if Yes then Please mention details of Supply / Erection / Commissioning)
Client Remark with Sign & Stamp. (If require attach supplement)	Rajwade 16/04/2012
Suggestions to Client	Plant Aceto Dont start
Complaint attend by (Name of Service Engg)	A) Pravin Pawase B)
Work Started from Date & Time Work Finished to Date & Time	16/4/12 in time = 11:30 out time = 6:00

**FOR WATER & WASTE WATER TREATMENT EQUIPMENTS
BHOSARI, PUNE - 411039.**

Cell No. : +91 - 9372701801 / +91 - 9850909688 / +91 - 9922740227 / +91 - 32009688
service@watertreatmentindia.net / contact@watertreatmentindia.net

Client Name	J.S.P.M
Site Name & Address	Wagholi
Type of Plant	CLARIFFIR/PSF/ACF/SOFT/RO/DM/MB/ETP/STP
Type of Service	Supply/Erection/Commissioning/After Sales-Service/ After Warrantee/Old Plant/Service for others plant
Capacity or other details of plant. (i.e Dia/Hos/Piping/Valves/Pumps/Etc.)	S.T.P. 500 m ³ /day
Concern Person & designation	Mr. Radandev
Contact No. of Concern Person & Site	mob. 7387415830
Complaints or Observation in Plant/Systems (If require attach supplement)	Plant Auto Not working
Work Carried out or Action taken by Service engineer (If require attach supplement)	Raw water pump float switch checked
Material / Spares delivered (Pls attach acknowledge copy of Delivery Challan or description of goods)	Yes / No. float switch
Require material / spares or Service next time. (If yes then mention description of Goods & type of service)	Yes / No.
Plant within Warrantee ?	Yes / No (if Yes then Please mention details of Supply / Erection / Commissioning)
Client Remark with Sign & Stamp. (If require attach supplement)	Revised 18/04/12
Suggestions to Client	1) Raw water pump float valve check & cleaning (2) Time to time Sludge drum & filter back wash
Complaint attend by (Name of Service Engg)	A) Pravin Pawade B)
Work Started from Date & Time	18/4/12 in time 14:30
Work Finished to Date & Time	out time 15:30

**FOR WATER & WASTE WATER TREATMENT EQUIPMENTS
BHOSARI, PUNE - 411039.**

Cell No. : +91 - 9372701801 / +91 - 9850909688 / +91 - 9922740227 / +91 - 32009688
service@watertreatmentindia.net / contact@watertreatmentindia.net

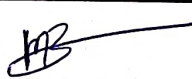
Client Name	J.S.P.M. INSTITUTES
Site Name & Address	Wagholi
Type of Plant	CLARIFFIR/PSF/ACF/SOFT/RO/DM/MB/ETP/STP
Type of Service	Supply/Erection/Commissioning/After Sales-Service/ After Warrantee/Old Plant/Service for others plant
Capacity or other details of plant. (i.e Dia/Hos/Piping/Valves/Pumps/Etc.)	S.T.P 500m ³ /day
Concern Person & designation	Mr. Bhave Sh
Contact No. of Concern Person & Site	mob - 7798015424
Complaints or Observation in Plant/Systems (If require attach supplement)	Electrical Problem
Work Carried out or Action taken by Service engineer (If require attach supplement)	S.T.P controls Panel All electrical material change & - All Pumps & Blower check is ok
Material / Spares delivered (Pls attach acknowledge copy of Delivery Challan or description of goods)	Yes / No. A.P.S Churns
Require material / spares or Service next time. (If yes then mention description of Goods & type of service)	Yes / No.
Plant within Warrantee ?	Yes / No (if Yes then Please mention details of Supply / Erection / Commissioning)
Client Remark with Sign & Stamp. (If require attach supplement)	
Suggestions to Client	
Complaint attend by (Name of Service Engg)	A) Pravin Pawade B)
Work Started from Date & Time Work Finished to Date & Time	26/4/12 in Time = 10:00 out Time = 15:30

**FOR WATER & WASTE WATER TREATMENT EQUIPMENTS
BHOSARI, PUNE - 411039.**

Cell No. : +91 - 9372701801 / +91 - 9850909688 / +91 - 9922740227 / +91 - 32009688
service@watertreatmentindia.net / contact@watertreatmentindia.net

WTE Infra Projects Pvt. Ltd.

PAP S-77, Nr Bridgestone Company, MIDC Ph-II - Chakan, Village Sawardari, Tq. Khed,
 Pune - 410501 Country INDIA
 STD 020
 E-Mail: accounts@wteinfra.com

DELIVERY CHALLAN/PACKING SLIP

Party :
 J0011 - JAYWANT SHIKSHAN PRASARK MANDAL - WAGHOL
 Pune Nagar Road
 Wagholi Campus Wagholi
 Pune - 412207
Contact Person : Balaji Mali
Mobile No : 09823123456 **Tel :**

Doc. No. : PCKSP2223000763
Date : 08 August 2022
Ref No. : JSPM/RO
Ref Date : 18 July 2022
Project No : SER1699

Consignee :
 JAYWANT SHIKSHAN PRASARK MANDAL - WAGHOLI
 Pune Nagar Road
 Wagholi Campus Wagholi
 Pune - 412207

Sr. No	Description of the Item(s)	UOM	Quantity	Rate
1	RMCMCI0004 - CARTRIDGE FILTER - 4" X 20"	NOS	6.000	
2	RMCMMV0006 - MPV SMS RM - 40 NB	NOS	1.000	

Narration : Invoice No - INVDM2223000301 Date - 06.08.2022 Material Cost - 11800/-

Commissionerate Pune-II
Division IV(Chakan-II)
Range IV(CHAKAN-IX)
F.C.C No. AA.ECK4133BEM002
VAT TIN No. 27421148585V Dt //
ESI TIN No. Dt //

For WTE Infra Projects Pvt. Ltd.

Authorized Signatory

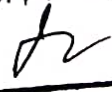
OUTWARD
Date : 21/8/22
Material Time: 10150
SL No.: 3052
Invoice No.: 762
Vehicle No.: MH14JL9680
Name & Sign of security: 

J S P M Wagholi
Inward No 1440
Date 21/8/22
Time 12:35 PM
veh No MH14JL9680
Name Security
LCshjngardc

WTE Infra Projects Pvt. Ltd.

PAP S-77, Nr Bridgestone Company, MIDC Ph-II - Chakan, Village Sawardari, Tq. Khed,
 Pune - 410501 Country INDIA
 STD 020
 E-Mail: wte@wteinfra.com

DELIVERY CHALLAN/PACKING SLIP

Party : J0011 - JAYWANT SHIKSHAN PRASARK MANDAL - WAGHOL Pune Nagar Road Wagholi Campus Wagholi Pune - 412207 Contact Person : Balaji Mali Mobile No : 09823123456 Tel :		Doc. No. : PCKSP2223000763 Date : 08 August 2022 Ref No. : JSPM/RO Ref Date : 18 July 2022 Project No : SER1699	
Consignee : JAYWANT SHIKSHAN PRASARK MANDAL - WAGHOL Pune Nagar Road Wagholi Campus Wagholi- Pune 412207			

Sr. No	Description of the Item(s)	LOT	UOM	Quantity	Rate
1	RMCMCF0004 - CARTRIDGE FILTER - 4" X 20"		NOS	6.000	
2	RMCMMV0006 - MPV SMS RM - 40 NB		NOS	1.000	

Narration : Invoice No - INVDM2223000301 Date - 06.08.2022 Material Cost - 11800/-

Commissionerate : Pune-II
 Division : IV(Chakan-II)
 Range : IV(CI(AKAN-IX))
 F. C. C No. : AA.ECK4133BEM002
 VAT TIN No. : 27421148585V Dt: //
 CST TIN No. : Dt: //

For WTE Infra Projects Pvt Ltd

 Authorised Signatory

OUTWARD
 Date: 2/8/22
 Material Time: 10150
 SL No.: 3052
 Invoice No.: 762
 Vehicle No.: MH15JL9680
 Name & Sign of security: *[Signature]*

J S P M Wagholi
 Inward No: 144
 Date: 08/08/22
 Time: 12:35 PM
 Veh No: MH15JL9680
 Name: *[Signature]*
 ISecurity: LCshingardc



WTE Infra Projects Pvt. Ltd.

PAP S-77, Nr Bridgestone Company, MIDC Ph-II Chakan, Village Sawardari, Tq. Khed,
Pune - 410501 Country: INDIA
STD 020 -
E-Mail : wteaccounts@wteinfra.com

DELIVERY CHALLAN/PACKING SLIP

Party :

J0011 - JAYWANT SHIKSHAN PRASARK MANDAL - WAGHOL
Pune Nagar Road
Wagholi Campus Wagholi
Pune - 412207

Doc. No. : PCKSP2223000761

Date : 06 August 2022

Ref No. : JSPM/RO

Ref Date : 01 August 2022

Project No : SER1708

Contact Person : Balaji Mali
Mobile No : 09823123456 Tel :

Consignee :

JAYWANT SHIKSHAN PRASARK MANDAL - WAGHOL
Pune Nagar Road
Wagholi Campus Wagholi-
Pune - 412207

Sr. No Description of the Item(s)

LOT

UOM

Quantity

Rate

1 RMCMCH0020 - HYDROCHLORIC ACID

LTR

40.000

Narration : Invoice no -INVDM2223000299 date - 06.08.2022 Amount - 2400/-

Commissionerate : Pune-II
Division : IV(Chakan-II)
Range : IV(CHAKAN-IX)
F.C.C No : AAECK4133BEM002
VAT TIN No. : 27421148585V
CSI TIN No. : Dt: //
Dt: //

For WTE Infra Projects Pvt. Ltd.

Authorised Signatory

S P M Wagholi
Jwam No 1618
Date 8/8/2022
Time 12:35 PM
Veh No MH14JL9688
Name [Signature]
[Signature]
[Signature]

OUTWARD
Date 8/8/22
Material Time: 10:50
SL No.: 2051
Invoice No.: 761
Vehicle No.: MH14JL9688
Name & Sign of security: [Signature]

LOKESH MAIPATIL

Prepared By

Verified By

Approved By

Received By



Jayawant Shikshan Prasarak Mandal

Wagholi Campus, Pune

Prof. Tanaji Sawant
FOUNDER SECRETARY

Gat. No. 720 (1&2), Wagholi, Pune-Nagar Road, Pune-412 207..Ph. 020 - 67335100 Fax : 67335100

PURCHASE ORDER

To, WTE Infra Projects Pvt.Ltd, S. No 80/1, Bhosari Alandi Road, Magazine Corner, Behind Hotel Pragati Wadmukhwadi,Charholi (B), Pune-412 105.	P.O. No.: JSPM/RO Plant/PUR/186/21-22. Date:- 18/07/2022 Delivery of Material by 20/07/2022 at college address
--	---

Dear Sir/Madam,

With reference to your quotation submitted by you and subsequent correspondence and discussion it's our pleasure to place this purchase order for the supply of items as per the list given below on the terms & conditions stated

Sr. no.	DESCRIPTION	Total(Rs)
1	Multiport Valve Side Mounted Softner size- 40 NB	6700.00
2	PP Spun type cartridge Filter Size- 4x20"	5100.00
GST 18 %		2124.00
Total Amount with GST		13924.00

Total Rs. (in words:- Thirteen thousand nine hundred twenty four Only)

Terms and conditions

30 days credit payment

Delivery- within 2 week

Transportation- Extra in Client scope.

P& F – Included.

Accepted Purchase Order No: JSPM/RO Plants /PUR/186/21-22. Authorized Signature: Name:- WTE Infra Projects Pvt.Ltd. Signature	On Behalf of Management JSPM  18/07/2022 CAMPUS DIRECTOR Jayawant Shikshan Prasarak Mandal's Wagholi, Pune - 412 207.
---	---

Material Description:-

Sr. No.	Description	Quantity	Rate Per Unit	Total Amount
1.	Multiport Valve Side Mounted Softener Size - 40 NB	1 Nos	6,700/-	6,700/-
2.	PP Spun Type Cartridge Filter Size - 4x20"	6 Nos	850/-	5,100/-
			TOTAL	11,800/-
			GST 18%	Extra

NOTES:-

1. Once material delivers at site with invoice it will not be corrected if some changes required then it should be at the time of Sale Order Acceptance.
2. Our scope is only supply of material.
3. If required any extra material, then it will charge extra.
4. Please mention transportation scope in your PO.

Commercial Details:-

- Unloading : By Client
- Insurance : NA
- Payment : 30 Days Credit
- GST 18% : Extra at actual
- Transportation : Included
- E & C : NA
- P & F : Included
- Delivery : Two to three week from the date of approved PO
- Offer Validity : 30 days
- HSN Code : 84219900



Jayawant Shikshan Prasarak Mandal

Wagholi Campus, Pune

Prof. Tanaji Sawant
FOUNDER SECRETARY

Gat. No. 720 (1&2), Wagholi, Pune-Nagar Road, Pune-412 207., Ph. 020 - 27051170 to 75 Fax : 020- 27052590

PURCHASE ORDER

To, WTE Infra Projects Pvt.Ltd. S. No 26/6, Apte Colony Pune-Nashik Road, Behind Ayyappa Temple, Bhosari Pune – 411039.	P.O. No.: JSPM/STP Plant/PUR/186721-22. Date:-18/07/2022 Delivery of Material by 20/07/2022 at college address
---	---

Dear Sir/Madam,

With reference to your quotation submitted by you and subsequent correspondence and discussion it's our pleasure to place this purchase order for the supply of items as per the list given below on the terms & conditions stated

Sr. no.	DESCRIPTION	Total(Rs)
1	Deformer	38000.00
Total		38000.00
GST 18 %		6840.00
Total Amount with GST		44840.00

Total Rs. (in words:- Fourty four thousand eight hundred forty only)

Terms and conditions

30 days credit payment
Delivery- within 2 week
Transportation- Extra in Client scope.
P& F – Included.

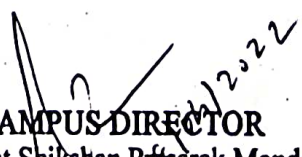
Accepted Purchase Order No: JSPM/STP Plants /PUR/186721-22. Authorized Signature: Name:- WTE Infra Projects Pvt.Ltd. Signature	On Behalf of Management JSPM  CAMPUS DIRECTOR Jayawant Shikshan Prasarak Mandal's Wagholi, Pune - 412 207.
--	--

Material Description:-

Sr. No.	Description	Quantity	Rate Per Unit	Total Amount
1.	Defoamer	40 Ltr	950/-	38,000/-
			TOTAL	38,000/-
			GST 18%	Extra

NOTES:-

1. Once material delivers at site with invoice it will not be corrected if some changes required then it should be at the time of Sale Order Acceptance.
2. Our scope is only supply of material.
3. Proper material storage will be in client scope.

Commercial Details:-

- Unloading : By Client
- Insurance : NA
- Payment : 30 Days Credit.
- GST 18% : Extra at actual
- Transportation : Included
- E & C : NA
- P & F : Included
- Delivery : 2 Week from the date of approved PO
- Offer Validity : 30 days
- HSN Code : 84219900

Note:- Above Description is based on our project range basis, and to overcome mismatch of HSN and SAC Code



Jayawant Shikshan Prasarak Mandal

Wagholi Campus, Pune

Prof. Tanaji Sawant
FOUNDER SECRETARY

Gat. No. 720 (1&2), Wagholi, Pune-Nagar Road, Pune-412 207., Ph. 020 - 67335100 Fax : 67335100

Ref. No:- JSPM/WGL/RO/2021-22/

दिनांक:- १४/०४/२०२२

प्रती,
मा . संस्थापक सचिव,
जयवंत शिक्षण प्रसारक मंडळ,
मध्यवर्ती कार्यालय,
कात्रज, पुणे .

विषय:- वॉटर प्लॅन्टसाठी मटेरिअल मागविलेल्या खर्चास परवानगी मिळणेबाबत...

महोदय,

उपरोक्त विषयास अनुसरून वाघोली संकुलामधील(RO)वॉटर प्लॅन्टसाठी खालील मटेरिअल मागविण्यात आले असून त्याचा तपशील खालील प्रमाणे आहे .

Sr. No	Name of Material	Bill No	Qty.	Amount
1	MPV SMF RM - 40 NB		1	44500.00
2	HYDROCHLORIC ACID		10 Liter	
3	EDTA		5 KG	
4	CITRIC ACID		5 KG	
5	CAUSTIC SODA		5 KG	
6	ANTISCALENT A-101		10 LTR	
Toatl				44500.00
CGST 9%				4005.00
SGST 9%				4005.00
Total Amount				52510.00

तरी कृपया सदर वीलास मंजूरी मिळावी ही नम्र विनंती .

➤ सोबत :- वील जोडत आहे .

संकुल संचालक

मा . संस्थापक सचिव
जयवंत शिक्षण प्रसारक मंडळ

TAX INVOICE

ORIGINAL

Rule 7 of Section 31

WTE Infra Projects Pvt. Ltd.

Works PAP S-77,Nr Bridgestone Company,MIDC Ph-II - ,Chakan,Village
Pune - 410501-INDIA
STD 020 -
E-Mail : wteaccounts@wteinfra.com/wteaccounts@wteinfra.com
Contact No- +91 7720079688



Range : IV(CHAKAN-IX) Division : IV(Chakan-II) Commissionerate : Pune-II GST NO : 27AAECK4133B1Z0 PAN : AAFCK4133B Our Bank Details : Axis Bank Ltd Corporate Banking Branch Pune IFSC Code: UTIB0001636 MICR No.411211027 A/c No- 917030029264377	Invoice No : INVDM2223000008 Date : 11/04/2022 Date Of Removal : 11/04/2022 Time Of Removal : 5:29 S O No. & Date : SOSER2223000006-09/04/2022 P O No. & Date : JSPM/RO Plant/PUR/1837/21-22.-09/04/2022 Proj. Engineer : TAKIK TANAJI LAXMAN Chalan No Packing List
Ship To Party J0011 - JAYWANT SHIKSHAN PRASARK MANDAL - WAGHOL Pune Nagar Road Wagholi Campus Wagholi Pune - 412207	Bill To Party :J0011 - JAYWANT SHIKSHAN PRASARK MANDAL - WAGHOL Pune Nagar Road Wagholi Campus Wagholi Pune - 412207 - Maharashtra GST NO : 27 PAN NO Vehicle No : LR No : Date : Transpoter Name : Nature of removal :Industrial Consumer Category : Independ Buyer

Sr. No	Description of the Material(s)	HSN Code	UOM	Qty	Rate	Basic Amount	IGST % Amount	CGST % Amount	SGST % Amount	Total
1	FGWWEF0053 - Repair and Maintenance service for RO Project No : SER1610	995468	Nos	1.000000	44500.00	44500.00	0.00	0.00 9.00	4005.00 9.00	44,500.00
Total :					1.000000	44500.00	0.00	4005.00	4005.00	44,500.00

Total Amount before Tax In Words : Rupees Forty - Four Thousand Five Hundred Only.	Total : 44,500.00
Taxes : Disc : P & F Freight : Others : Freight Insurance : Others Tcs : R. Off Narration : Bond No. :	IGST : 0.00 CGST : 4005.00 SGST : 4005.00 Grand Total : 52,510.00
Total Amount Chargable in words : Rupees Fifty - Two Thousand Five Hundred Ten Only.	

I/We hereby certify that my/our registration certificate under the GST Act 2017 is in force on the date on which the sale of good specified in this "Tax Invoice" is made by me/us and that the transaction of sale covered by this "Tax Invoice" has been effected by me/us and it shall be accounted for the turnover of sale while filling of return and the due tax, if any, payable on the sale has been paid or shall be paid.
 if payment of this bill is not received with due date, interest @24%P.A will be collected from you in addition to the bill amount
 Subject to Pune Jurisdiction Only

Certified that the particular given above are true and correct and the amount represents the price actually charged and there is no flow of additional consideration directly or indirectly from the buyer
 "Goods received in good condition as per bill"
 J S P M Wagholi
 Name : J S P M Wagholi
 Date : 11/04/2022
 Sign. :
 Mod. No. :
 Seal :
 Time :
 Vehicle No :
 Name :

For WTE Infra Projects Pvt. Ltd.
 KRUSHNA SHINDE
 (Authorised Signatory)

 Page 1 of 1



WTE Infra Projects Pvt. Ltd.

WTE INFRA PROJECTS PVT. LTD.

Address - CHAKAN MIDC PAHSE - II
Telefax: +91 020 32669688 , 32009688 Cell: 9372701801, 9822110661

DELIVERY CHALLAN

To		JAYWANT SHIKSHAN PRASARK MANDAL WAGHOLI	DATE:- 12.04.2022	
		PUNE	Challan NO - 2022-23/ 027	
		PUNE NAGAR ROAD		
		WAGHOLI CAMPUS WAGHOLI		
		PUNE-412207		
Delivery Adress		JAYWANT SHIKSHAN PRASARK MANDAL WAGHOLI	Ref By : SER1610	
		PUNE		
		PUNE NAGAR ROAD		
		WAGHOLI CAMPUS WAGHOLI		
		PUNE-412207		
Sr.No.	Part Code	Description	Quantity	Unit
1	RMCMV0005	MPV SMF RM - 40 NB	1	NOS
2	RMCMCH0020	HYDROCHLORIC ACID	10	LTR
3	RMCMCH0028	EDTA	5	KG
4	RMCMCH0018	CITRIC ACID	5	KG
5	RMCMCH0017	CAUSTIC SODA	5	KG
6	RMCMCH0010	ANTISCALENT A-101	10	LTR

For WTE Infra Project Pvt.Ltd.

Receiver's Sign with Stamp

Authorized Signatory

J S P M Waghori
Inward No: 51/04
Date: 13.04.2022
Time: 1:10 pm
Veh No: MH14FD9688
Name:

OUTWARD
Date: 13/4/22
Material Time: 1110
SL No.: 2282
Invoice No: 027
Vehicle No.: MH14 FD 9688
Name & Sign of security:



Jayawant Shikshan Prasarak Mandal

Wagholi Campus, Pune

Prof. Tanaji Sawant

FOUNDER SECRETARY

Gat. No. 720 (1&2), Wagholi, Pune-Nagar Road, Pune-412 207., Ph. 020 - 67335100 Fax : 67335100

PURCHASE ORDER

To, WTE Infra Projects Pvt.Ltd, S. No 80/1, Bhosari Alandi Road, Magazine Corner, Behind Hotel Pragati Wadmukhwadi, Charholi (B), Pune-412 105.	P.O. No.: JSPM/RO Plant/PUR/1852 /21-22. Date:- 29/05/2022 Delivery of Material by 30/05/2022 at college address
---	---

Dear Sir/Madam,

With reference to your quotation submitted by you and subsequent correspondence and discussion it's our pleasure to place this purchase order for the supply of items as per the list given below on the terms & conditions stated

Sr. no.	DESCRIPTION	Total(Rs)
1	Dosing Pump – 0-6 LPH Make-E-Dose/Eqv	9700.00
	GST 18 %	1746.00
	Total Amount with GST	11446.00

Total Rs. (in words:- Eleven thousand four hundred forty six Only)

Terms and conditions

30 days credit payment

Delivery- within 2 week

Transportation- Extra in Client scope.

P& F – Included.

Accepted Purchase Order No:
JSPM/RO Plants /PUR/ 1852 /21-22.
Authorized Signature:
Name:- WTE Infra Projects Pvt.Ltd.

Signature

On Behalf of Management JSPM

Campus Director
Jayawant Shikshan Prasarak Mandal
Wagholi, Pune - 412 207.



WTE Infra Projects Pvt. Ltd.

For Water And Waste Water Treatment System

(Formerly known as WTE-Water Treatment Equipments Pune)



ENQ-SER-22-23-00086/R1

DATE: 24/05/2022

TO,
JSPM Wagholi

Kind Attention : Mr. Yuvraj Kamble

E-mail : yuvrajkamble13@gmail.com

Subject : Techno Commercial offer for Dosing Pump.

With reference to your Enquiry Here with we are pleased to submit our Techno Commercial offer for Dosing Pump.

The following annexure form a part of this offer.

- Annexure – I : Specification & Bill of Material
- Annexure – II : Price
- Annexure – III : Commercial Terms & Condition

Looking forward to receive your valuable order and assures you our best service.

Yours faithfully,
WTE INFRA PROJECTS PVT LTD,
Laxmi Pounikar
9850726688

WTE GST NO: - 27AAECK4133B1

Office & Factory Add : PAP-S-77, Nr Bridgestone Company, MIDC Phase II, Chakan, Village Sawardari, Tal. Khed, Dist. Pune - 410 501.

+91-8378968812 hr@wteinfra.com www.wteinfra.com

Support for Enquires & Services : + 91+888889611/22

Material Description:-

Sr. No.	Description	Quantity	Rate Per Unit	Total Amount
1.	Dosing Pump – 0-6 LPH Make - E-Dose/Eqv	1 No	9,700/-	9,700/-
			TOTAL	9,700/-
			GST 18%	Extra

NOTES:-

1. Once material delivers at site with invoice it will not be corrected if some changes required then it should be at the time of Sale Order Acceptance.
2. Our scope is only supply of material.
3. If required any extra material, then it will charge extra.
4. Please mention transportation scope in your PO.

Commercial Details:-

- Unloading : By Client
- Insurance : NA
- Payment : 30 Days Credit
- GST 18% : Extra at actual
- Transportation : Included
- E & C : NA
- P & F : Included
- Delivery : Two to three week from the date of approved PO
- Offer Validity : 30 days
- HSN Code : 84219900

Please mention payment terms in P.O.



Jayawant Shikshan Prasarak Mandal

Wagholi Campus, Pune

Prof. Tanaji Sawant

FOUNDER SECRETARY

Gat. No. 720 (1&2), Wagholi, Pune-Nagar Road, Pune-412 207., Ph. 020 - 27051170 to 75 Fax : 020- 27052590

PURCHASE ORDER

To, WTE Infra Projects Pvt.Ltd. S. No 26/6, Apte Colony Pune-Nashik Road, Behind Ayyappa Temple, Bhosari Pune – 411039.	P.O. No.: JSPM/STP Plant/PUR/ 1853 /21-22. Date:-07/06/2022 Delivery of Material by 08/06/2022 at college address
---	--

Dear Sir/Madam,

With reference to your quotation submitted by you and subsequent correspondence and discussion it's our pleasure to place this purchase order for the supply of items as per the list given below on the terms & conditions stated

Sr. no.	DESCRIPTION	Total(Rs)
1	Air Blower Servicing Includes: Bearing.Oiling,greasing and oil seal replacement.	15000.00
2	Safety Valve Size- 2"	16600.00
Total		31600.00
GST 18 %		5688.00
Total Amount with GST		37288.00

Total Rs. (in words:- Thirty seven thousand two hundred eighty eight only)

Terms and conditions

30 days credit payment

Delivery- within 2 week

Transportation- Extra in Client scope.

P& F – Included.

Accepted Purchase Order No: JSPM/STP Plants /PUR/ 1853 /21-22. Authorized Signature: Name:- WTE Infra Projects Pvt.Ltd. Signature	On Behalf of Management JSPM Campus Director Jayawant Shikshan Prasarak Mandal Wagholi, Pune - 412 207.
---	--

Material Description:-

Sr. No.	Description	Quantity	Rate Per Unit	Total Amount
1.	Air Blower Servicing Includes: Bearing, oiling, greasing and oil seal replacement (Excluding: - Gear, lobes, rotor or any other major parts replacement) Model- M5175	1 Job	15,000/-	15,000/-
2.	Safety Valve Size- 2"	1 No	16,600/-	16,600/-
			TOTAL	31,600/-
			GST 18%	Extra

NOTES:-

1. Once material delivers at site with invoice it will not be corrected if some changes required then it should be at the time of Sale Order Acceptance.
2. If required extra material during serving, then it will charge extra.
3. Please mention transportation scope in your PO.

Commercial Details:-

- Unloading : By Client
- Insurance : NA
- Payment : 30 Days Credit
- GST 18% : Extra at actual
- Transportation : Included
- E & C : NA
- P & F : Included
- Delivery : Two to three week from the date of approved PO
- Offer Validity : 30 days
- HSN Code : 99546800



Please mention payment terms in P.O.

In case you have any queries please feel free to contact us.

Looking forward to receive your valuable order and assures you our best service.

Yours Faithfully,

WTE INFRA PROJECT PVT. LTD

TAX INVOICE

ORIGINAL

Rule 7 of Section 31

WTE Infra Projects Pvt. Ltd.

Works : PAP S-77,Nr Bridgestone Company,MIDC Ph-II - ,Chakan,Village
Pune - 410501-INDIA
STD 020 -
E-Mail : wteaccounts@wteinfra.com/wteaccounts@wteinfra.com
Contact No- +91 7720079688



Range : IV(CHAKAN-IX)
Division : IV(Chakan-II)
Commissionerate : Pune-II
GST NO : 27AAECK4133B1Z0
PAN : AAECK4133B
Our Bank Details : Axis Bank Ltd
Corporate Banking Branch Pune
IFSC Code: UTIB0001636
MUR No.411211027 /vc No- 91703002926437

Invoice No : INVDM2122000701 Date : 21/12/2021
Date Of Removal : 21/12/2021
Time Of Removal : 16:53

S O No. & Date : SOSER2122000171-16/12/2021
P O No. & Date :
JSPM/RO Plant/PUR/1809/20-22-07/12/2021

Proj. Engineer : TAKIK TANAJI LAXMAN
Chalan No Packing List

Ship To Party
J0011 - JAYWANT SHIKSHAN PRASARK MANDAL - WAGHOL
Pune Nagar Road
Wagholi Campus Wagholi

Bill To Party :
J0011 - JAYWANT SHIKSHAN PRASARK MANDAL -
Pune Nagar Road
Wagholi Campus Wagholi

Pune - 412207 - Maharashtra
GST NO : 27 PAN NO :

Vehicle No :
Date :
LR No. :
Transpoter Name :
Nature of removal : Industrial Consumer Category : Independ Buyer
GST Notfn No

412207

Sr. No	Description of the Material(s)	HSN Code	UOM	Qty	Rate	Basic Amount	IGST % Amount	CGST % Amount	SGST % Amount	Total
1	FGWWEF0052 - REPAIR AND MAINTENANCE SERVICE FOR RO Project No. SER1522	995468	NO	1.000000	52450.00	52450.00	0.00	0.00 9.00	4720.50 9.00	52,450.00
Total				1.000000	52450.00	0.00	4720.50	4720.50	52,450.00	

Total Amount before Tax In Words : Rupees Fifty-two Thousand Four Hundred Fifty Only.	Total : 52,450.00
Taxes :	IGST : 0.00
Disc: P & F	CGST : 4720.50
Freight	SGST : 4720.50
Insurance	
Tcs	
Narration :	
Bond No. :	Grand Total : 61,891.00

Total Amount Chargeable in words : Rupees Sixty-one Thousand Eight Hundred Ninety-one Only.

J S P M Wagholi
Inward No *S7/12*
Date *22/12/2021*
Time *02:25 PM*
Veh No *MH 14 B 119688*
Name *(Signature)*

We hereby certify that my/our registration-certificate under the GST Act 2017 is in force on the date on which the sale of good specified in this "Tax Invoice" is made by me/us and that the transaction of sale covered by this "Tax Invoice" has been effected by me/us and it shall be accounted for the turnover of sale while filling of return and the due tax, if any, payable on the sale has been paid or shall be paid.
1. If payment of this bill is not received with due date, interest @24%P.A. will be collected from you in addition to the bill amount.
2. Subject to Pune Jurisdiction Only

Certified that the particular given above are true and correct and the amount represents the price actually charged and there is no flow of additional consideration directly or indirectly from the buyer
"Goods received in good condition as per bill"
Name _____
Recd. sign. _____
Mob.No. _____
Seal _____

For WTE Infra Projects Pvt. Ltd.
NILESH DHEMBARE
(Authorised Signatory)
(Signature)
Page 1 of 1

WTE Infra Projects Pvt. Ltd.



PAP S-77, Nr Bridgestone Company, MIDC Ph-II - , Chakan, Village Sawardari, Tq. Khed,
Pune - 410501 Country: INDIA
STD 020 -
E-Mail : wteaccounts@wteinfra.com

DELIVERY CHALLAN/PACKING SLIP

Party : J0011 - JAYWANT SHIKSHAN PRASARK MANDAL - WAGHOL Pune Nagar Road Wagholi Campus Wagholi Pune - 412207 Contact Person : Balaji Mali Mobile No : 09823123456 Tel :	Doc. No. : PCKSP2122001463 Date : 21 December 2021 Ref No. : JSPM/RO Ref Date : 07 December 2021 Project No : SER1522
--	---

Consignee :
 JAYWANT SHIKSHAN PRASARK MANDAL - WAGHOL
 Pune Nagar Road
 Wagholi Campus Wagholi-
 Pune - 412207

Sr. No	Description of the Item(s)	LOT	UOM	Quantity	Rate
1	CMFCCM0015 - HARDNESS TEST KIT		NOS	1.000	
2	CMFCCM0016 - CHLORINE TEST KIT		NOS	1.000	
3	RMCMCF0004 - CARTRIDGE FILTER - 4" X 20"		NOS	6.000	
4	RMCMCH0017 - CAUSTIC SODA		KG	5.000	
5	RMCMCH0018 - CITRIC ACID		KG	5.000	
6	RMCMCH0019 - SODIUM LOARY SULPHATE		KG	2.000	
7	RMCMCH0028 - EDTA		KG	5.000	
8	RMINPH0008 - TDS METER- PEN TYPE		NOS	1.000	

Narration :

Commissionerate : Pune-II	
Division : IV(Chakan II)	For WTE Infra Projects Pvt. Ltd.
Range : IV(CHAKAN-IX)	
E. C. C. No. : AAECK4133BEM002	
VAT TIN No. : 27421148585V	Dt: //
CS1 TIN No. :	Dt: //

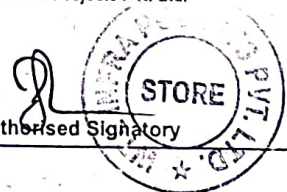

J S P M Wagholi
 Inward No. 57/12
 Date 22/12/2021
 Time 02:25 PM
 Veh No MAH HM 9688
 Name [Signature]

WTE INFRA PROJECTS PVT. LTD.
 Material Outward
 Gate Entry No. 1511
 Ch. No. 1463 Ch. Date 21.12
 Outward Date 22.12.21
 Outward Timing 11.50 Vehicle No. MAH 14 007
 Signature [Signature] 9688

Prepared By: LOKESH MALIPATIL
 Verified By: _____
 Approved By: _____
 Received By: [Signature] 22/12/21



WTE Infra Projects Pvt. Ltd.

PAP S-77, Nr Bridgestone Company, MIDC Ph-II - , Chakan, Village Sawardari, Tq. Khed,
 Pune - 410501 Country: INDIA
 STD 020 -
 E-Mail : wteaccounts@wteinfra.com

DELIVERY CHALLAN/PACKING SLIP

Party :
 J0011 - JAYWANT SHIKSHAN PRASARK MANDAL - WAGHOL
 Pune Nagar Road
 Wagholi Campus Wagholi
 Pune - 412207

Doc. No. : PCKSP2122001926
 Date : 03 March 2022

Contact Person : Balaji Mali
 Mobile No : 09823123456 Tel :

Ref No. : JSPM/RO
 Ref Date : 07 December 2021
 Project No : SER1522

Consignee :
 JAYWANT SHIKSHAN PRASARK MANDAL - WAGHOL
 Pune Nagar Road
 Wagholi Campus Wagholi-
 Pune - 412207

No	Description of the Item(s)	LOT	UOM	Quantity	Rate
1	RMCIDF0001 - DIAPHRAGM VALVE EL - 25 NB		NOS	1.000	
2	RMCMCH0001 - SODIUM HYPOCHLORIDE		LTR	40.000	

Commissionerate : Pune-II
 Division : IV(Chakan-II)
 Range : IV(CHAKAN-IX)
 E.C.C No. : AAECK4133BEM002
 VAT TIN No. : 27421148585V Dt: //
 CST TIN No. : Dt: //

For WTE Infra Projects Pvt. Ltd.
 Authorised Signatory

J S P M Wagholi
 Invoice No. 12
 Date 04/03/2022
 Time 04:15 PM
 Veh. No MH14 FS 0599
 Name [Signature]
 (Security)

WTE INFRA PROJECTS PVT. LTD.
 Material Outward
 Gate Entry No 1993
 Ch. No. 1926 Date 04/03/22
 Outward Date 4/3/22
 Outward Timing 4:30 Vehicle No MH14
 Signature [Signature] 0989688



Jayawant Shikshan Prasarak Mandal

Wagholi Campus, Pune

Prof. Tanaji Sawant
FOUNDER SECRETARY

Gat. No. 720 (1&2), Wagholi, Pune-Nagar Road, Pune-412 207., Ph. 020 - 27051170 to 75 Fax : 020- 27052590

PURCHASE ORDER

To,
WTE Infra Projects Pvt.Ltd.
S. No 26/6, Apte Colony Pune-Nashik Road,
Behind Ayyappa Temple,
Bhosari Pune – 411039.

P.O. No.: JSPM/STP Plant/PUR/1840/21-22.
Date:-23/04/2022
Delivery of Material by 25/04/2022 at college
address

Dear Sir/Madam,

With reference to your quotation submitted by you and subsequent correspondence and discussion it's our pleasure to place this purchase order for the supply of items as per the list given below on the terms & conditions stated

Sr. no.	DESCRIPTION	Total(Rs)
1	Chemical	21200.00
Total		21200.00
GST 18 %		3816.00
Total Amount with GST		25016.000

Total Rs. (in words:- Twenty five thousand sixteen only)

Terms and conditions

30 days credit payment

Delivery- within 2 week

Transportation- Extra in Client scope.

P& F – Included.

Accepted Purchase Order No:
JSPM/STP Plants /PUR/ 1840 /21-22.
Authorized Signature:
Name:- WTE Infra Projects Pvt.Ltd.

Signature

On Behalf of Management JSPM

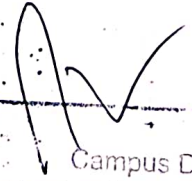
Campus Director
Jayawant Shikshan Prasarak Mandal
Wagholi, Pune - 412 207.

Material Description:-

Sr. No.	Description	Quantity	Rate Per Unit	Total Amount
1.	Sodium Hypochlorite	40 Ltr	55/-	2,200/-
2.	Defoamer	20 Ltr	950/-	19,000/-
			TOTAL	21,200/-
			GST 18%	Extra

NOTES:-

1. Once material delivers at site with invoice it will not be corrected if some changes required then it should be at the time of Sale Order Acceptance.
2. Our scope is only supply of material.

Commercial Details:-

- Unloading : By Client
- Insurance : NA
- Payment : 30 Days Credit
- GST 18% : Extra at actual
- Transportation : Extra
- E & C : NA
- P & F : Included
- Delivery : 2 Week from the date of approved PO
- Offer Validity : 30 days
- HSN Code : 84219900

Please mention payment terms in P.O.

In case you have any queries please feel free to contact us.



Jayawant Shikshan Prasarak Mandal

Wagholi Campus, Pune

Prof. Tanaji Sawant

FOUNDER SECRETARY

Gat. No. 720 (1&2), Wagholi, Pune-Nagar Road, Pune-412 207., Ph. 020 - 67335100 Fax : 67335100

PURCHASE ORDER

To, WTE Infra Projects Pvt.Ltd, S. No 80/1, Bhosari Alandi Road, Magazine Corner, Behind Hotel Pragati Wadmukhwadi, Charholi (B), Pune-412 105.	P.O. No.: JSPM/RO Plant/PUR/1732/20-21. Date:05/08/2021 Delivery of Material by 7/08/2021 at college address
---	---

Dear Sir/Madam,

With reference to your quotation submitted by you and subsequent correspondence and discussion it's our pleasure to place this purchase order for the supply of items as per the list given below on the terms & conditions stated

Sr. no.	DESCRIPTION	Total(Rs)
1	Repair and Maintenance service for RO SAC Code- 995468	18590.00
	GST 18 %	3346.20
	Total Amount with GST	21936.00

Total Rs. (in words:- Twenty one thousand nine hundred thirty six Only)

Terms and conditions

30 days credit payment
Delivery- within 2 week
Transportation- Extra in Client scope.
P& F - Included.

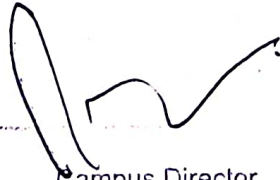
Accepted Purchase Order No: JSPM/RO Plants /PUR/ 1732/20-21. Authorized Signature: Name:- WTE Infra Projects Pvt.Ltd. Signature	On Behalf of Management JSPM  Campus Director Jayawant Shikshan Prasarak Mandal Wagholi, Pune - 412 207.
---	--



WTE Infra Projects Pvt. Ltd.

For Water And Waste Water Treatment System

(Formerly known as WTE-Water Treatment Equipments Pune)



ENQ-SER-2021-000182

DATE: 04/08/2021

To
JSPM WAGHOLI

Kind Attention : Mr. Yuvraj Kamble

E-mail : yuvrajkamble13@gmail.com

Subject : Chemical consumable for RO plant.

With reference to your Enquiry Here with we are pleased to submit our techno-commercial offer for Spares.

The following annexure form a part of this offer.

- Annexure – I : Specification & Bill of Material
- Annexure – II : Price
- Annexure – III : Commercial Terms & Cor.dition
- Annexure – IV : Client List

Looking forward to receive your valuable order and assures you our best service.

Yours faithfully,

WTE INFRA PROJECTS PVT LTD,
Aparna Kadam

9850726688

WTE GST NO: - 27AAECK4133B1Z0



Material Description:-

Sr. No	Description	Quantity	Rate per unit	Total amount
1.	Caustic Soda	5 Kg	340/-	1,700/-
2.	EDTA	5 kg	620/-	3,100/-
3.	Citric Acid	5 Kg	425/-	2,125/-
4.	HCL	10 Lit	55/-	550/-
5.	SLS	2 Kg	545/-	1,090/-
6.	Sodium Hypochlorite	10 Lit	55/-	550/-
7.	Antiscalent A-101	5 Lit	495/-	2,475/-
8.	Servicing Charges and Transportation Charges	1 Lot	7000/-	7,000/-
			Total	18,590/-
			GST 18 %	Extra

NOTES:

1. Once material delivers at site with invoice it will not be corrected if some changes required then it should be at the time of Sale Order Acceptance.
2. If any material required during servicing then will be extra charges.
3. If required unskilled man power is in client scope.

Commercial Details:-

- Unloading : By Client
- Insurance : NA
- Payment : 30 days credit
- GST 18% : Extra at actual
- Transportation : Included
- E & C : NA
- P & F : Included
- Delivery : Two to Three Week from the date of approved PO

WTE Infra Projects Pvt. Ltd.



PAP S-77,Nr Bridgestone Company,MIDC Ph-II - ,Chakan,Village Sawardari,Tq.Khed,
Pune - 410501 Country: INDIA
E-Mail : wteaccounts@wteinfra.com

DELIVERY CHALLAN/PACKING SLIP

Party :
J0011 - JAYWANT SHIKSHAN PRASARK MANDAL - WAGHOL
Pune Nagar Road
Wagholi Campus Wagholi
Pune - 412207
Contact Person : Balaji Mall
Mobile No : 09823123456 Tel :
GST No :
PAN :
State Code :

Doc. No. : PCKSP2021001550
Date : 04 March 2021
Date of Dispatch :
Ref No. : JSPM/RO
Ref Date : 26 February 2021
Project No : SER1319

Consignee :
JAYWANT SHIKSHAN PRASARK MANDAL - WAGHOL
Pune Nagar Road
Wagholi Campus Wagholi-
Pune - 412207

Sr.	Description of the Item(s)	LOT	UOM	Quantity	Rate	HSN Code
1	ICMCH0018 - CITRIC ACID		KG	5.00		

Narration :

GST No : 27AAECK4133B1ZO
PAN : 410501

For WTE Infra Projects Pvt. Ltd.

Authorised Signatory

JSPM Wagholi
Inward No. 24/03
Date 05/03/21
Time 12:20 PM
Jah No BY RAHUL
7

TAX INVOICE

Original For Buyer

Rule 7 of Section 31

WTE Infra Projects Pvt. Ltd.

Works : PAP S-77,Nr Bridgestone Company,MIDC Ph-II - ,Chakan,Village Sawardari,Tq.Khed
Pune - 410501-INDIA

STD 020 -

E-Mail : wteaccounts@wteinfra.com/wteaccounts@wteinfra.com
Contact No- +91 7720079688



Range : IV(CHAKAN-IX)	Invoice No : INVDM2021000801	Date : 04/03/2021
Division : IV(Chakan-II)	Date Of Removal : 04/03/2021	
Commissionerate : Pune-II	Time Of Removal : 9:42	
GST NO : 27AAECK4133B1Z0	S O No. & Date : SOSER2021000231-03/03/2021	
PAN : AAECK4133B	P O No. & Date : JSPM/RO Plant/PUR/1765/20-21-26/02/2021	
Our Bank Details : Axis Bank Ltd Corporate Banking Branch Pune IFSC Code: UTIB0001636 MICR No.411211027 A/c No- 917030029264377	Proj. Engineer : TEJAS TULARAM SHETIYE	
	Chalan No Packing List	

Ship To Party J0011 - JAYWANT SHIKSHAN PRASARK MANDAL - WAGHOL Pune Nagar Road Wagholi Campus Wagholi Pune - 412207 - Maharashtra	Bill To Party : J0011 - JAYWANT SHIKSHAN PRASARK MANDAL - WAGHOL Pune Nagar Road Wagholi Campus Wagholi Pune - 412207 - Maharashtra GST NO : 27	Vehicle No : Date : LR No. : Date : Transpoter Name : Nature of removal : Industrial Consumer Category : Independ Buyer GST Notfn No
--	---	--

Sr. No	Description of the Material(s)	HSN Code	UOM	Qty	Rate	Basic Amount	IGST % Amount	CGST % Amount	SGST % Amount	Total			
1	FGSPSM0021 - CITRIC ACID FOR RO CIP Project No : SER1319	84219900	KG	5.000000	425.00	2125.00	0.00	0.00	9.00	191.25	9.00	191.25	2,125.00
Total :				5.000		2125.00	0.00		191.25		191.25		2,125.00

Total Amount before Tax In Words : Rupees Two Thousand One Hundred Twenty-five Only.	Total : 2,125.00
Taxes : Disc : P & F Aed : Freight Others : Freight Insurance : Others Tcs : R. Off Narration : Bond No. :	IGST : 0.00 CGST : 191.25 SGST : 191.25 Grand Total : 2,508.00

Total Amount Chargable in words : Rupees Two Thousand Five Hundred Eight Only.

J S P M Wagholi
 Invoice No: 21103
 Date: 04-03-2021
 Time: 12:20 PM
 Chalan No: by hand
 Name: [Signature]

I/We hereby certify that my/our registration certificate under the GST Act 2017 is in force on the date on which the sale of good specified in this "Tax Invoice" is made by me/us and that the transaction of sale covered by this "Tax Invoice" has been effected by me/us and it shall be accounted for the turnover of sale while filing of return and the due tax, if any, payable on the sale has been paid or shall be paid. 1. if payment of this bill is not received with due date, interest @24%P.A. will be collected from you in addition to the bill amount. 2. Subject to Pune Jurisdiction Only	Certified that the particular given above are true and correct and the amount represents the price actually charged and there is no flow of additional consideration directly or indirectly from the buyer "Goods received in good condition as per bill" Name Recd. sign. Mob.No. Seal	For WTE Infra Projects Pvt. Ltd. PUNE NILESH CHEMBARE (Authorized Signatory)
---	---	---

मेटेरिअल रिपोर्ट

प्रति,
मा. संकुल संचालक,
जयवर्ग शिक्षण प्रसारक मंडळ,
वाघोली रूणे.

अर्जदार :- समाधान प्रभाकर ऊंबळे

विषय :- कालेल्या मेटेरिअलच्या ok.
Report बाबत.

महोदय,

वरील विषयात अनुसकून आपल्या वाघोली या
शैक्षणिक संकुला मधील R.O. प्लान्ट साठी
Citric acide 5 kg हवे होते ते किर्नाळ
26/2/2021 रोजी मागविले होते ते मागिलेल्या
प्रमाण मिळाले त्याचा हा ok Report आपणाकडे
सादर करत आहे.

कळावे
आपला विश्वासू
समाधान
ऊंबळे समाधान प्रभाकर



Jayawant Shikshan Prasarak Mandal

Wagholi Campus, Pune

Prof. Tanaji Sawant

FOUNDER SECRETARY

Gat. No. 720 (1&2), Wagholi, Pune-Nagar Road, Pune-412 207., Ph. 020 - 67335 100 Fax : 67335 100

PURCHASE ORDER

To, WTE Infra Projects Pvt.Ltd, S. No 80/1, Bhosari Alandi Road, Magazine Corner, Behind Hotel Pragati Wadmukhwadi, Charholi (B), Pune-412 105.	P.O. No.: JSPM/RO Plant/PUR/1765/20-21. Date:26/02/2021 Delivery of Material by 27/02/2021 at college address
---	--

Dear Sir/Madam,

With reference to your quotation submitted by you and subsequent correspondence and discussion it's our pleasure to place this purchase order for the supply of items as per the list given below on the terms & conditions stated

Sr. no.	DESCRIPTION	Total(Rs)
1	Repair and Maintenance service for RO SAC Code- 995468	2125.00
	GST 18 %	382.50
	Total Amount with GST	2507.50
	Round off	2507.00

Total Rs. (in words:- Two thousand five hundred seven Only)

Terms and conditions

30 days credit payment

Delivery- within 2 week

Transportation- Extra in Client scope.

P& F - Included.

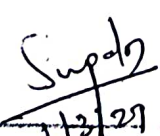
Accepted Purchase Order No: JSPM/RO Plants /PUR/ 1765 /20-21. Authorized Signature: Name:- WTE Infra Projects Pvt.Ltd.	On Behalf of Management JSPM  17/2/21
Signature	Campus Director Jayawant Shikshan Prasarak Mandal Wagholi, Pune - 412 207.



Material Description:-

Sr. No	Description	Quantity	Rate per unit	Total amount
1.	Citric Acid for RO CIP	5 Kg	425/-	2,125/-
		Total		2,125/-
		GST 18%		Extra

NOTES:-

1. Once material delivers at site with invoice it will not be corrected if some changes required then it should be at the time of Sale Order Acceptance.
2. Our Scope is in only supply of material.

Commercial Details:-

- Unloading : By Client
- Insurance : NA
- Payment : 100% advance along with approved PO.
- GST 18% : Extra at actual
- Transportation : Extra
- E & C : NA
- P & F : NA
- Warranty : NA
- Delivery : Ex – Stock, Chakan Pune
- HSN Code : 84219900

Note: - Above Description is based on our project range basis, and to overcome mismatch of HSN and SAC Code

Please mention payment terms in P.O.



Jayawant Shikshan Prasarak Mandal

Wagholi Campus, Pune

Prof. Tanaji Sawant
FOUNDER SECRETARY

Gat. No. 720 (1&2), Wagholi, Pune-Nagar Road, Pune-412 207., Ph. 020 - 67335100 Fax : 67335100

Ref. No:- JSPM/WGL/RO/2020-21/1748

दिनांक:- 08/02/2021

प्रती,
मा . संस्थापक सचिव,
जयवंत शिक्षण प्रसारक मंडळ,
मध्यवर्ती कार्यालय,
कात्रज ,पुणे .

विषय:- वॉटर प्लॅन्टसाठी मीठ खरेदी करण्यास परवानगी मिळणेबाबत...

महोदय,

उपरोक्त विषयास अनुसरून वाघोली संकुलामधील वॉटर प्लॅन्टसाठी मीठाची आवश्यकता आहे . वॉटर प्लॅन्टसाठी लागणारे मीठ Benzer Multitech India Pvt Ltd. यांच्याकडून नेहमी घेतो . आता त्यांच्याकडून 2000kg. मीठ घेण्यासाठी रू . १०,०००/- खर्च येत आहे . तरी कृपया मीठ मागविण्यास परवानगी मिळावी ही नम्र विनंती .

❖ सोबत कोटेशन जोडत आहे .

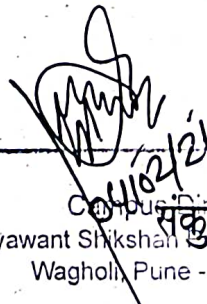
Campus Director
Jayawant Shikshan Prasarak Mandal
Wagholi, Pune - 412 207.
सकुल संचालक

Benzer Multitech India Pvt Ltd

Wed, Feb 3, 3:53 PM (23 hours ago)

to me

Hello Sir/ Ma'am

Please find below offer quotation:(MOQ 2000 Kg)

Salt@ Rs 5/ Kg Delivered at your site Wagholi

Terms & Conditions :

- 1) Payment :Advance
- 2) Delivery Period : Immediate Delivery



Jayawant Shikshan Prasarak Mandal

Wagholi Campus, Pune

Prof. Tanaji Sawant

FOUNDER SECRETARY

Gat. No. 720 (1&2), Wagholi, Pune-Nagar Road, Pune-412 207..Ph. 020 - 67335100 Fax : 67335100

PURCHASE ORDER

To, WTE Infra Projects Pvt.Ltd, S. No 80/1, Bhosari Alandi Road, Magzine Corner, Behind Hotel Pragati Wadmukhwadi, Charholi (B), Pune-412 105.	P.O. No.: JSPM/RO Plant/PUR/ 174/20-21. Date:30 /01/2021 Delivery of Material by 01/02/2021 at college address
--	---

Dear Sir/Madam,

With reference to your quotation submitted by you and subsequent correspondence and discussion it's our pleasure to place this purchase order for the supply of items as per the list given below on the terms & conditions stated

Sr. no.	DESCRIPTION	Total(Rs)
1	Repair and Maintenance service for RO SAC Code- 995468	23390.00
	GST 18 %	4210.20
	Total Amount with GST	27600.20
	Round off	27600.00

Total Rs. (in words:- Twenty seven thousand six hundred Only)

Terms and conditions

30 days credit payment

Delivery- within 2 week

Transportation- Extra in Client scope.

P& F – Included.

Accepted Purchase Order No: JSPM/RO Plants /PUR/ 174/ 20-21. Authorized Signature: Name:- WTE Infra Projects Pvt.Ltd. Signature	On Behalf of Management JSPM  Campus Director Jayawant Shikshan Prasarak Mandal Wagholi, Pune - 412 207.
---	--



Jayawant Shikshan Prasarak Mandal

Wagholi Campus, Pune

Prof. Tanaji Sawant

FOUNDER SECRETARY

Gat. No. 720 (1&2), Wagholi, Pune-Nagar Road, Pune-412 207..Ph. 020 - 67335100 Fax : 67335100

PURCHASE ORDER

To, WTE Infra Projects Pvt.Ltd, S. No 80/1, Bhosari Alandi Road, Magazine Corner, Behind Hotel Pragati Wadmukhwadi,Charholi (B), Pune-412 105.	P.O. No.: JSPM/RO Plant/PUR/1683/19-20. Date:12 /06/2020 Delivery of Material by 13/06/2020 at college address
--	---

Dear Sir/Madam,

With reference to your quotation submitted by you and subsequent correspondence and discussion it's our pleasure to place this purchase order for the supply of items as per the list given below on the terms & conditions stated

Sr. no.	DESCRIPTION	Total(Rs)
1	Repair and Maintenance service for RO SAC Code- 995468	19970.00
	GST 18 %	3594.60
	Total Amount with GST	23564.60
	Round off	23565.00

Total Rs. (in words:- Twenty three thousand five hundred sixty five Only)

Terms and conditions

30 days credit payment

Delivery- within 2 week

Transportation- Extra in Client scope.

P& F – Included.

Accepted Purchase Order No: JSPM/RO Plants /PUR/ 1683 /19-20. Authorized Signature: Name:- WTE Infra Projects Pvt.Ltd. Signature	On Behalf of Management JSPM  Campus Director Jayawant Shikshan Prasarak Mandal Wagholi, Pune - 412 207.
--	--



(Formerly known as WTE Water Treatment Equipments Pune)
WTE Infra Projects Pvt. Ltd.
For Water And Waste Water Treatment Systems



Factory Address: PAP-S - 77, Nr. Bridgestone Company, MIDC Phase - II, Sawardari Village, Chakan, Tal - Khed, Dist - Pune - 410 501.

ENQ-SER-2021-0000186R1

DATE: 29/01/2021

To,
JSPM Wagholi

Kind Attention : Mr. Yuvraj Kamble
E-mail : yuvrajkamble13@gmail.com
Subject : Offer for RO Cleaning Chemical.

With reference to your Enquiry Here with we are pleased to submit our techno-commercial offer for spares.

The following annexure form a part of this offer.

- Annexure - I : Specification & Bill of Material
- Annexure - II : Price
- Annexure - III : Commercial Terms & Condition
- Annexure - IV : Client List

Looking forward to receive your valuable order and assures you our best service.

Yours faithfully,

WTE INFRA PROJECTS PVT LTD,

Aparna Kadam

9850726688

WTE GST NO: - 27AAECK4133B1Z0

Office & Factory Add : PAP-S-77, Nr Bridgestone Company, MIDC Phase II, Chakan, Village Sawardari, Tal. Khed, Dist. Pune - 410 501.

+91-8378968812 | hr@wteinfra.com | www.wteinfra.com | f | t | y | l | k

Support for Enquiries & Services : + 91+8888889611/22



Material Description:-

Sr. No	Description	Quantity	Rate per unit	Total amount
1.	Caustic Soda	5 Kg	340/-	1,700/-
2.	EDTA	5 kg	620/-	3,100/-
3.	Citric Acid	5 Kg	425/-	2,125/-
4.	HCL	10 Lit	55/-	550/-
5.	SLS	2 Kg	545/-	1,090/-
6.	Sodium Hypochlorite	10 Lit	55/-	550/-
7.	Antiscalent A-101	5 Lit	495/-	2,475/-
8.	PP Spun type Cartridge Filter Size - 4 x 20	6 No	800/-	4,800/-
6.	Servicing Charges and Transportation Charges	1 Lot	7000/-	7,000/-
			Total	23,390/-
			GST 18 %	Extra

NOTES:-

- 1) Once material delivers at site with invoice it will not be corrected if some changes required then it should be at the time of Sale Order Acceptance.
- 2) If any material required during servicing it should be extra charges.
- 3) Unskilled man power is in client scope.
- 4) Proper material storage is in client scope.

Commercial Details:-

- Unloading : By Client
- Insurance : NA
- Payment : 30 Days Credit
- GST 18% : Extra
- Transportation : Included
- E & C : NA
- P & F : Included



- Delivery : Two to Three Week from the date of approved PO
- SAC Code : 995468

Note: - Above Description is based on our project range basis, and to overcome mismatch of HSN and SAC Code.

Please mention payment terms in P.O.

In case you have any queries please feel free to contact us.

Looking forward to receive your valuable order and assures you our best service.

P|Yours Faithfully,

WTE INFRA PROJECT PVT. LTD

OUR FEW CLIENTS

- PROCIENT ENGG PVT LTD, MYANMAR
- MARJ EXPORT PVT LTD, UGANDA
- JAL ECOTECH (I) PVT LTD, NAGPUR
- UNIVERSAL ENGINEERING & ENVIRO SOLUTIONS, PUNE
- SAINT GOBAIN INDIA PVT LTD, WADA
- GLOBAL ENVIRO TECH SERVICES, PUNE
- HABER WATER TECHNOLOGIES LLP, PUNE
- NAMRATA DEVELOPERS PVT.LTD. (ECO CITY), PUNE
- NYATI ENGINEERS & CONSULTANTS, BANGALORE
- KOLTE PATIL DEVELOPERS LTD(KPDL) , PUNE
- PIMPRI CHINCHWAD MUNICIPAL CORPORATION
- PIDILITE INDUSTRIES LTD
- BHAIKAVNATH SUGAR WORK LTD
- GBMT STEEL SERVICES LLC, DUBAI



Jayawant Shikshan Prasarak Mandal

Wagholi Campus, Pune

Prof. Tanaji Sawant

FOUNDER SECRETARY

Gat. No. 720 (1&2), Wagholi, Pune-Nagar Road, Pune-412 207..Ph. 020 - 67335100 Fax : 67335100

PURCHASE ORDER

To, WTE Infra Projects Pvt.Ltd, S. No 80/1, Bhosari Alandi Road, Magazine Corner, Behind Hotel Pragati Wadmukhwadi, Charholi (B), Pune-412 105.	P.O. No.: JSPM/RO Plant/PUR/1683/19-20. Date: 12/06/2020 Delivery of Material by 13/06/2020 at college address
---	---

Dear Sir/Madam,

With reference to your quotation submitted by you and subsequent correspondence and discussion it's our pleasure to place this purchase order for the supply of items as per the list given below on the terms & conditions stated

Sr. no.	DESCRIPTION	Total(Rs)
1	Repair and Maintenance service for RO SAC Code- 995468	19970.00
	GST 18 %	3594.60
	Total Amount with GST	23564.60
	Round off	23565.00

Total Rs. (in words:- Twenty three thousand five hundred sixty five Only)

Terms and conditions

30 days credit payment
Delivery- within 2 week
Transportation- Extra in Client scope.
P& F – Included.

Accepted Purchase Order No: JSPM/RO Plants /PUR/ 1683 /19-20. Authorized Signature: Name:- WTE Infra Projects Pvt.Ltd. Signature	On Behalf of Management JSPM  Campus Director Jayawant Shikshan Prasarak Mandal Wagholi, Pune - 412 207.
--	---



(Formerly known as WTE Water Treatment Equipments Pune)
WTE Infra Projects Pvt. Ltd.
For Water And Waste Water Treatment Systems



Factory Address: PAF 5 - 77, Nr. Dodgestone Company, MIDC Phase - II, Sawardan Village, Chakan, Tal - Khed, Dist - Pune - 410 401

ENQ-SER-2021-0087

DATE-11/06/2020

To,

JSPM Wagholi

E-mail : yuvrajkamble13@gmail.com

**KindAttention : Mr. YuvrajKamble(9850559037)
Mr. samadhankamble(9527633550)**

Subject : Techno commercial offer for spares and service

Project : JSPM Wagholi(RO)

With reference to your Enquiry Here with we are pleased to submit our techno-commercial offer for spares and Service.

Material requirement as per below, and your purchase order should be described like below

Purchase Order Name:-

Sr No	Description	Total amount
A.	Repair and maintenance Service including supply of spares.	19,970/-
B.	GST 18%	Extra at actual.

SAC Code: - 995468

WTE GST NO: - 27AAECK4133B1Z0.

Note: - Above Description is based on our project range basis, and to overcome mismatch of HSN and SAC Code, detail material description are as below.



Material Description:-

Sr.No	Description	Quantity	Rate per unit	Total amount
1	HCL	10 Lit	55/-	550/-
2	Caustic soda	5 Kg	340/-	1700/-
3	EDTA	5 Kg	620/-	3100/-
4	CITRIC ACID	5 Kg	425/-	2125/-
5	SLS	1 Kg	545/-	545/-
6	Antiscallent A-101	10 Lit	495/-	4950/-
7	Servicing charges	1 Lot	5000/-	5000/-
8	Transportation charges	1 set	2000/-	2000/-
			Total	19,970/-
			GST 18%	Extra

Note:-

- 1) If any material required during servicing it will charge extra.
- 2) Once material delivers at site with invoice it will not be corrected if some changes required then it should be at the time of Sale Order Acceptance.
- 3) Unskilled manpower is in client scope if required.
- 4) Proper material storage is in client scope.
- 5) Used Media Disposal is in client scope.

Commercial Details:-

SGST: -9%

CGST: -9%

Transportation: -Included.

P & F: - Included

Delivery: - One to two weeks.

Payment: - 30 days credit

Please mention payment terms in P.O.

In case you have any queries please feel free to contact us.

Looking forward to receive your valuable order and assures you our best service.

Yours Faithfully,



Jayawant Shikshan Prasarak Mandal

Wagholi Campus, Pune

Prof. Tanaji Sawant

FOUNDER SECRETARY

Gat. No. 720 (1&2), Wagholi, Pune-Nagar Road, Pune-412 207., Ph. 020 - 67335 100 Fax : 67335 100

PURCHASE ORDER

To, WTE Infra Projects Pvt.Ltd, S. No 80/1, Bhosari Alandi Road, Magazine Corner, Behind Hotel Pragati Wadmukhwadi, Charholi (B), Pune-412 105.	P.O. No.: JSPM/RO Plant/PUR/1656/19-20. Date:30 /01/2020 Delivery of Material by 31/01/2020 at college address
---	---

Dear Sir/Madam,

With reference to your quotation submitted by you and subsequent correspondence and discussion it's our pleasure to place this purchase order for the supply of items as per the list given below on the terms & conditions stated

Sr. no.	DESCRIPTION	Total(Rs)
1	Repair and Maintenance service for RO SAC Code- 995468	17495.00
GST 18 %		3149.10
Total Amount with GST		20644.00

Total Rs. (in words:- Twenty thousand six hundred forty four Only)

Terms and conditions

30 days credit payment

Delivery- within 2 week

Transportation- Extra in Client scope.

P & F - Included.

Accepted Purchase Order No: JSPM/RO Plants /PUR/ 1656 /19-20. Authorized Signature: Name:- WTE Infra Projects Pvt.Ltd. Signature	On Behalf of Management JSPM  Campus Director Jayawant Shikshan Prasarak Mandal Wagholi, Pune - 412 207.
--	--



(Formerly known as WTE Water Treatment Equipments Pune)
WTE Infra Projects Pvt. Ltd.
For Water And Waste Water Treatment Systems



Factory Address: PAP-S - 77, Nr. Bridgestone Company, MIDC Phase - II, Sawardan Village, Chakan, Tal - Khed, Dist - Pune - 410 501

ENQSER-1920-00298

DATE: 29/01/2020

To,
JSPM Wagholi

E-mail : yuvrajkamble13@gmail.com

Kind Attention : Mr. Yuvraj Kamble (9850559037)
Mr. samadhankamble (9527633550)

Subject : Techno commercial offer for spares and service

Project : JSPM Wagholi (RO)

With reference to your Enquiry Here with we are pleased to submit our techno-commercial offer for spares and Service.

Material requirement as per below, and your purchase order should be described like below

Purchase Order Name:-

Sr No	Description	Total amount
A.	Repair and maintenance Service including supply of spares.	17,495/-
B.	GST 18%	Extra at actual.

SAC Code: - 995468

WTE GST NO: - 27AAECK4133B1Z0.

Note: - Above Description is based on our project range basis, and to overcome mismatch of HSN and SAC Code, detail material description are as below.

Registered Office Address: 26/6, Acte Colony, Behind Ayappa Temple, Bhosari, Pune - 411 039. CIN - U41000PN2011PTC140129
Sales & Marketing Office: 80/1, Bhosari-Alandi Road, Magazine Corner, Behind Hotel Pragati Wadmkhwadi, Charholi(B), PCMC, Pune - 412 105. ☎ +91 7350010552, M helpline@watertreatmentindia.net

Support for Enquires & Services : + 91 888889611, 888889622



Material Description:

Sr.No	Description	Quantity	Rate per unit	Total amount
1	HCL	10 Lit	55/-	550/-
2	Caustic soda	5 Kg	340/-	1700/-
3	EDTA	5 Kg	620/-	3100/-
4	CITRIC ACID	5 Kg	425/-	2125/-
5	SLS	1 Kg	545/-	545/-
6	Antiscallent A-101	5 Lit	495/-	2475/-
7	Servicing charges	1 Lot	5000/-	5000/-
8	Transportation charges	1 set	2000/-	2000/-
			Total	17,495/-
			GST 18%	Extra

Note:

- 1) If any material required during servicing it will charge extra.
- 2) Once material delivers at site with invoice it will not be corrected if some changes required then it should be at the time of Sale Order Acceptance.
- 3) Unskilled manpower is in client scope if required.
- 4) Proper material storage is in client scope.
- 5) Used Media Disposal is in client scope.

Commercial Details:-

SGST: - 9%

CGST: - 9%

Transportation: - Included.

P & F: - Included

Delivery: - One to two weeks.

Payment: - 30 days credit

Please mention payment terms in P.O.

In case you have any queries please feel free to contact us.

Looking forward to receive your valuable order and assures you our best service.

Yours Faithfully,



Jayawant Shikshan Prasarak Mandal

Wagholi Campus, Pune

Prof. Tanaji Sawant

FOUNDER SECRETARY

Gat. No. 720 (1&2), Wagholi, Pune-Nagar Road, Pune-412 207., Ph. 020 - 27051170 to 75 Fax : 020- 27052590

PURCHASE ORDER

To, WTE Infra Projects Pvt.Ltd. S. No 26/6, Apte Colony Pune-Nashik Road, Behind Ayyappa Temple, Bhosari Pune – 411039.	P.O. No.: JSPM/STP Plant/PUR/1611/19-20. Date:-03/12/2019 Delivery of Material by 05/12/2019 at college address
---	--

Dear Sir/Madam,

With reference to your quotation submitted by you and subsequent correspondence and discussion it's our pleasure to place this purchase order for the supply of items as per the list given below on the terms & conditions stated

Sr. no.	DESCRIPTION	Total(Rs)
1	Chemical	14845.00
Total		16825.00
GST 18 %		3028.50
Total Amount with GST		19853.50

Total Rs. (in words:- Nineteen Thousand eight hundred fifty three only)

Terms and conditions

30 days credit payment

Delivery- within 2 week

Transportation- Extra in Client scope.

P & F – Included.

Accepted Purchase Order No: JSPM/STP Plants /PUR/ 1611 /19-20. Authorized Signature: Name:- WTE Infra Projects Pvt.Ltd. Signature	On Behalf of Management JSPM  Campus Director Jayawant Shikshan Prasarak Mandal Wagholi, Pune - 412 207.
---	---



(Formerly known as WTE Water Treatment Equipments Pune)
WTE Infra Projects Pvt. Ltd.
For Water And Waste Water Treatment Systems



Factory Address: PAP-S-77, Nr. Bridgestone Company, MIDC Phase-II, Sawardari Village, Chakan, Tal. - Khed, Dist. - Pune - 410 501

ENQSER-1920-000273

DATE: 29/11/2019

**To,
JSPM Wagholi**

Kind Attention : Mr. Mr. Yuvraj Kamble (9850559037)
Mr. samadhan kamble (9527633550)

E-mail : yuvrajkamble13@gmail.com / rmideule@gmail.com

Subject : Offer for Chemical

Project : WTP Plant

With reference to your Enquiry Here with we are pleased to submit our techno-commercial offer for spares.

The following annexure form a part of this offer.

- Annexure – I : Specification & Bill of Material
- Annexure – II : Price
- Annexure – III : Commercial Terms & Condition
- Annexure – IV : Client List

Looking forward to receive your valuable order and assures you our best service.

Yours faithfully,

WTE INFRA PROJECTS PVT LTD,

Aparna Kadam

9850726688

WTE GST NO: - 27AAECK4133B1Z0

Factory Address: PAP-S-77, Nr. Bridgestone Company, MIDC Phase II, Chakan Village Sawardari, Tal. Khed, Dist. Pune - 410 501

+91-8378968812 hr@wteinfra.com www.wteinfra.com   

Support for Enquires & Services : +91-888889611/22



Material Description:-

Sr.No	Description	Quantity	Rate per unit	Total amount
1.	Hypo	170 lit	55/-	9,350/-
2.	Deformer	10 lit	300/-	3000/-
3.	Transportation Charges	1 set	2000/-	2,000/-
			Total	14,350/-
			GST 18 %	Extra

NOTES:-

- 1) Our scope is only supply of material.
- 2) Once material delivers at site with invoice it will not be corrected if some changes required then it should be at the time of Sale Order Acceptance.

Commercial Details:-

- Unloading : By Client
- Insurance : NA
- Payment : 30 days credit
- GST : 18 % extra
- Transportation : Included
- E & C : NA
- P & F : Included
- Delivery : One to Two weeks from the date of Approved PO
- HSN Code : 84219900

Note: - Above Description is based on our project range basis, and to overcome mismatch of HSN and SAC Code.

Please mention payment terms in P.O.

In case you have any queries please feel free to contact us.



WTE Infra Projects Pvt. Ltd.
For Water And Waste Water Treatment Systems

(Formerly known as WTE-Water Treatment Equipments Pune)



Factory Address: PAP-S-77, Nr. Bridgeslone Company, MIDC, Phase II, Sawardari Village, Chakan, Tal. Khed, Dist. Pune - 410 501

ENQSER-1920-000275

DATE: 03/12/2019

To,
JSPM Wagholi

Kind Attention : Mr. Mr. Yuvraj Kamble (9850559037)
Mr. samadhan kamble (9527633550)

E-mail : yuvrajkamble13@gmail.com / rmideule@gmail.com

Subject : Offer for Chemical

With reference to your Enquiry Here with we are pleased to submit our techno-commercial offer for spares.

The following annexure form a part of this offer.

- Annexure - I : Specification & Bill of Material
- Annexure - II : Price
- Annexure - III : Commercial Terms & Condition
- Annexure - IV : Client List

Looking forward to receive your valuable order and assures you our best service.

Yours faithfully,

WTE INFRA PROJECTS PVT LTD,

Aparna Kadam

9850726688

WTE GST NO: - 27AAECK4133B1Z0

Office & Factory Add: PAP-S-77, Nr Bridgeslone Company, MIDC Phase II, Chakan, Village Sawardari, Tal. Khed, Dist Pune - 410 501.

+91-8378968812 hr@wteinfra.com www.wteinfra.com

Support for Enquires & Services : +91-8888889611/22



Material Description:-

Sr.No	Description	Quantity	Rate per unit	Total amount
1.	Antiscalant A 101	5 lit	495/-	2475/-
			Total	2475/-
			GST 18 %	Extra

NOTES:-

- 1) Our scope is only supply of material.
- 2) Once material delivers at site with invoice it will not be corrected if some changes required then it should be at the time of Sale Order Acceptance.

Commercial Details:-

- Unloading : By Client
- Insurance : NA
- Payment : 30 days credit
- GST : 18 % extra
- Transportation : Included
- E & C : NA
- P & F : Included
- Delivery : One to Two weeks from the date of Approved PO
- HSN Code : 84219900

Note: - Above Description is based on our project range basis, and to overcome mismatch of HSN and SAC Code.

Please mention payment terms in P.O.

In case you have any queries please feel free to contact us.

Looking forward to receive your valuable order and assures you our best service.

Yours Faithfully,



Jayawant Shikshan Prasarak Mandal

Wagholi Campus, Pune

Prof. Tanaji Sawant
FOUNDER SECRETARY

Gat. No. 720 (1&2), Wagholi, Pune-Nagar Road, Pune-412 207..Ph. 020 - 67335100 Fax : 67335100

Ref:- JSPM/campus/2019-20/1631

PURCHASE ORDER

To, WTE Infra Projects Pvt.Ltd, S. No 80/1, Bhosari Alandi Road, Magazine Corner, Behind Hotel Pragati Wadmukhwadi, Charholi (B), Pune-412 105.	P.O. No.: JSPM/RO Plant/PUR/ /19-20. Date: 10/12/2019 Delivery of Material by 11/12/2019 at college address
---	--

Dear Sir/Madam,

With reference to your quotation submitted by you and subsequent correspondence and discussion it's our pleasure to place this purchase order for the supply of items as per the list given below on the terms & conditions stated

Sr. no.	DESCRIPTION	Total(Rs)
1	Repair and Maintenance service for RO SAC Code- 995468	26020.00
	GST 18 %	4683.60
	Total Amount with GST	30703.60
	Round Off	30704.00

Total Rs. (in words:- Thirty thousand seven hundred four Only)

Terms and conditions

30 days credit payment
Delivery- within 2 week
Transportation- Extra in Client scope.
P& F - Included.

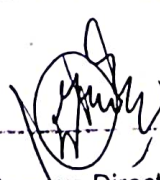
Accepted Purchase Order No: JSPM/RO Plants /PUR/ /19-20. Authorized Signature: Name:- WTE Infra Projects Pvt.Ltd. Signature	On Behalf of Management JSPM  Campus Director Jayawant Shikshan Prasarak Mandal Wagholi, Pune - 412 207.
---	---



WTE Infra Projects Pvt. Ltd.

For Water And Waste Water Treatment Systems

(Formerly known as WTE Water Treatment Equipments Pune)



Factory Address: PAFS-77, No. Engineering Company MIDC Phase - B, Sawarban Village, Chakan Tal. Khed Dist. Pune - 410 501

ENQSER-1920-00219

DATE: 02/10/2019

To,
JSPM Wagholi

E-mail : yuvrajkamble13@gmail.com

Kind Attention : Mr. Yuvraj Kamble (9850559037)
Mr. samadhan kamble (9527633550)

Subject : Techno commercial offer for spares and service

Project : JSPM Wagholi (RO)

With reference to your Enquiry Here with we are pleased to submit our techno-commercial offer for spares and Service.

Material requirement as per below, and your purchase order should be described like below

Purchase Order Name:-

Sr No	Description	Total amount
A.	Repair and maintenance Service including supply of spares.	26,020/-
B.	GST 18%	Extra at actual.

SAC Code: - 995468

WTE GST NO: - 27AAECK4133B1Z0.

Note: - Above Description is based on our project range basis, and to overcome mismatch of HSN and SAC Code, detail material description are as below.

Registered Office Address: 26/6, Apte Colony, Behind Ayappa Temple, Bhosari, Pune - 411 039. CIN - U41000PN2011PTC140129
Sales & Marketing Office: 80/1 Bhosari-Aland Road, Magzine Corner, Behind Hotel Pragat, Wadukhwad, Charholi(B), PCMC, Pune - 412 105. IS +91 7350010552, M helpline@watertreatmentindia.net

Support for Enquires & Services : + 91 8888889611, 8888889622



Material Description:-

Sr.No	Description	Quantity	Rate per unit	Total amount
1	Rota meter flange end 2 " 0 -7000 LPH with fitting	2 Nos	5500/-	11000/-
2	HCL	10 Lit	55/-	550/-
3	Caustic soda	5 Kg	340/-	1700/-
4	EDTA	5 Kg	620/-	3100/-
5	CITRIC ACID	5 Kg	425/-	2125/-
6	SLS	1 Kg	545/-	545/-
7	Servicing charges	1 Lot	5000/-	5000/-
8	Transportation charges	1 set	2000/-	2000/-
			Total	26,020/-

Note:-

- 1) If any material required during servicing it will charge extra.
- 2) Once material delivers at site with invoice it will not be corrected if some changes required then it should be at the time of Sale Order Acceptance.
- 3) Unskilled manpower is in client scope if required.
- 4) Proper material storage is in client scope.
- 5) Used Media Disposal is in client scope.

Commercial Details:-

SGST: - 9%

CGST: - 9%

Transportation: - Included.

P & F: - Included

Delivery: - One to two weeks.

Payment: - 30 days credit

Please mention payment terms in P.O.

In case you have any queries please feel free to contact us.

Looking forward to receive your valuable order and assures you our best service.

Yours Faithfully,



Jayawant Shikshan Prasarak Mandal

Wagholi Campus, Pune

Prof. Tanaji Sawant

FOUNDER SECRETARY

Gat. No. 720 (1&2), Wagholi, Pune-Nagar Road, Pune-412 207., Ph. 020 - 67335100 Fax : 67335100

Ref: - JSPM/campus/2019-20/1632

PURCHASE ORDER

To, WTE Infra Projects Pvt.Ltd, S. No 80/1, Bhosari Alandi Road, Magzine Corner, Behind Hotel Pragati Wadmukhwadi, Charholi (B), Pune-412 105.	P.O. No.: JSPM/RO Plant/PUR/ /19-20. Date: 10/12/2019 Delivery of Material by 11/12/2019 at college address
--	--

Dear Sir/Madam,

With reference to your quotation submitted by you and subsequent correspondence and discussion it's our pleasure to place this purchase order for the supply of items as per the list given below on the terms & conditions stated

Sr. no.	DESCRIPTION	Total(Rs)
1	Repair and Maintenance service for RO SAC Code- 995468	38500.00
	GST 18 %	38500.00
	Total Amount with GST	45430.00

Total Rs. (in words:- Forty five thousand four hundred thirty Only)

Terms and conditions

30 days credit payment

Delivery- within 2 week

Transportation- Extra in Client scope.

P& F – Included.

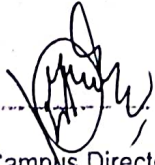
Accepted Purchase Order No: JSPM/RO Plants /PUR/ /19-20. Authorized Signature: Name:- WTE Infra Projects Pvt.Ltd. Signature	On Behalf of Management JSPM  Campus Director Jayawant Shikshan Prasarak Mandal Wagholi, Pune - 412 207.
---	--

अर्ज

प्रति,
मा. संकुल संचालक,
आयुर्वत विज्ञान प्रसारक मंडळ,
वाघोली पूणे.

विषय :- R.O. प्लांट साठी मटेरियल मागविण्या
बाबत.

महोदय,
वरील विषयास अनुसरून विनंती अर्ज करतो की
आपल्या वाघोली या बौद्धिक संकुलामधील R.O. प्लांट चे
Cartridge filter 4x20 संपले आहेत तरी ते मागविण्याचे
परवानगी मिळावी ही नम्र विनंती.
* पहिले Cartridge filter मागविलेली दिनांक 01/2/2018

कळवे
भास्मा विश्वासू
~~कांबळे~~
कांबळे समाधान

Permitto
Supd
5/4/19

TAX INVOICE
Rule 7 of Section 31

WTE INFRA PROJECTS P. LTD.

Works.: PAP S-77,Nr Bridgestone Company,MIDC Ph-II - ,Chakan,Village
Pune - 410501-INDIA



STD 020 -
E-Mail : wteaccounts@wteinfra.com
Contact No- +91 9822909688



Range : IV(CHAKAN-IX)
Division : IV(Chakan-II)
Commissionerate: Pune-II
GST NO : 27AAECK4133B1Z0
PAN : AAECK4133B
Our Bank Details: Bank Name : Axis Bank Ltd.
CC A/c No. : 917030029264377
Branch : Corporate Banking Branch Pune
IFSC Code- UTIB0001636
MICR No.411211027

Invoice No : INVDM1920000023 Date : 24/04/2019
Date Of Removal : 24/04/2019
Time Of Removal : 12: 4
S O No. & Date : SOSER1920000014-23/04/2019
P O No. & Date :
JSPM/RO PLANT/PUR/14-65/18-19-22/04/2019
Proj. Engineer :
Chalan No Packing:
List

ShipTo Party :
Jaywant Shikshan Prasark Mandal - Wagholi
Pune Nagar Road
Wagholi Campus Wagholi-
Pune - 412207

Bill To Party J0011 - Jaywant Shikshan Prasark Mandal - Wagholi
Pune Nagar Road
Wagholi Campus Wagholi
Pune - 412207 - Maharashtra
GST NO : 27
Vehicle No :
Date :
LR No. :
Transpoter Name :
Nature of removal Industrial Consumer - Category :Independ Buyer
GST Notfn No

Sr. No	Description of the Material(s)	HSN Code	UOM	Qty	Rate	Basic Amount	IGST % Amount	CGST % Amount	SGST % Amount	Total
1	FGSPSM0057 - MAINTENANCE OR REPAIR SERVICE FOR RO - MAINTENANCE OR REPAIR SERVICE FOR RO Project No : SER0756	9954	NOS	1.000	16550.00	16550.00	0.00	0.00	9.00 1489.50	9.00 1489.50 16,550.00
Total :					1.000	16550.00	0.00	1489.50	1489.50	16,550.00

Total Amount before Tax in Words : Rupees Sixteen Thousand Five Hundred Fifty Only.

Taxes :

Disc	P & F	IGST	: 0.00
Aed	Freight	CGST	: 1489.50
Others		SGST	: 1489.50
Insurance	Others		
Tcs	R. Off		
Narration :		Grand Total : 19,529.00	

Bond No. : Nineteen Thousand Five Hundred Twenty-nine Only.

Total Amount Chargeable in words : Rupees Nineteen Thousand Five Hundred Twenty-nine Only.

inward No 462804
Date 24/04/19
Time 02:15 P.M.
Veh No MH14EY4688
Name Securim

I/we hereby certify that my/our registration certificate under the GST Act 2017 is in force on the date on which the sale of good specified in this "Tax Invoice" is made by me/us and that the transaction of sale covered by this 'Tax Invoice' has been effected by me/us and it shall be accounted for the turnover of sale while filling of return and the due tax, if any, payable on the sale has been paid or shall be paid.
1. If payment of this bill is not received with due date, interest @24%P.A. will be collected from you in addition to the bill amount.
2. Subject to Pune Jurisdiction Only

Certified that the particular given above are true and correct and the amount represents the price actually charged and there is no flow of additional consideration directly or indirectly from the buyer

"Goods received in good condition as per bill"

Name _____ Resd. Sgn. _____ Mob.No. _____ Seal _____

For WTE INFRA PROJECTS P. LTD.
14
PRITAM KHILARI
(Authorised Signatory)





WTE INFRA PROJECTS P. LTD.

PAP S-77,Nr Bridgestone Company,MIDC Ph-II - ,Chakan,Village Sawardari,Tq.Khed,
Pune - 410501 Country: INDIA
E-Mail : wteaccounts@wteinfra.com

DELIVERY CHALLAN/PACKING SLIP

Party : J0011 - Jaywant Shikshan Prasark Mandal - Waghhol Pune Nagar Road Wagholi Campus Wagholi Pune - 412207 Contact Person : Balaji Mali Mobile No : 09823123456 Tel :	Doc. No. : PCKSP1920000046 Date : 24 April 2019 Date of Dispatch :
	Ref No. : JSPM/RO Ref Date : 22 April 2019 Project No : SER0756

Consignee :
Jaywant Shikshan Prasark Mandal - Waghhol
Pune Nagar Road
Wagholi Campus Wagholi-
Pune - 412207

Description of the Item(s)	LOT	UOM	Quantity	Rate	HSN Code
1. RMCMCF0004 - CARTRIDGE FILTER - 4" X 20"		NOS	10.00		
2. RMCMCH0010 - ANTISCALENT A-101		LTR	10.00		

Narration :

GST No : 27AAECK4133B1ZO PAN : 410501	For WTE INFRA PROJECTS P. LTD.  Authorized Signatory
--	--

J S P M Waghhol
Inward No **462/04**
Date **24/04/19**
Time **03:15 PM**
Veh No **MR12-099688**
Name **(Security)**

SANKET BARNE
Prepared By

Verified By

PRITAM KHILARI
Approved By

Geombus
24/4/19
Received By

TAX INVOICE Cum CHALLAN

AQUA PURE ENGINEERING Build. No.26, Flat No.11, Apte Colony, Bhosari Pune -411039 Ph. 020 27122852 / 32009688 E-mail : contact@watertreatmentindia.net	Invoice No.	Dated
	251	18-Nov-2010
	Delivery Note	Mode/Terms of Payment
Buyer J.S.P.M.S. Group of Institue Wagholi Campus, Wagholi, Pune Ph. 9763722100 9422037767	Supplier's Ref.	Against delivery Other Reference(s)
	Buyer's Order No.	Dated
	Verbal by Mr. Bugade	2-Sep-2010
Despatch Document No.	Dated	
Despatched through	Destination	
By Transport	Wagholi	
Terms of Delivery		

Sl No.	Description of Goods	Quantity	Rate	per	Disc. %	Amount
1	Water Treatment Plant Softning Plant - 15 M3/hr. RO Plant - 5 M3/hr.	1 Nos	10,00,000.00	Nos		10,00,000.00
	12.5% Output VAT		12.50	%		1,25,000.00
Total		1 Nos				11,25,000.00

Amount Chargeable (in words) E. & O.E
Rs. Eleven Lakh Twenty Five Thousand Only

Company's VAT TIN : 27100543869V w.e.f. 15-06-2006
 Company's CST No. : 27100543869C w.e.f. 15-06-2006
 Company's Service Tax No. : AAMFA7556MST001
 Company's PAN : AAMFA7556M

Declaration
 We hereby certify that our registration certificate under the Maharashtra Value Added Tax Act 2002 is in force on the date which the sale of goods specified in this tax invoice is made by me/us and that transaction of sales covered by this tax invoice has been effected by me/us and it shall be accounted for turnover of sales while filling of return and the due tax if any ,payble on the sales has been paid or shall be paid

for AQUA PURE ENGINEERING

 Authorized Signatory

This is a Computer Generated Invoice